

RENAISSANCE 3762- \_\_\_\_

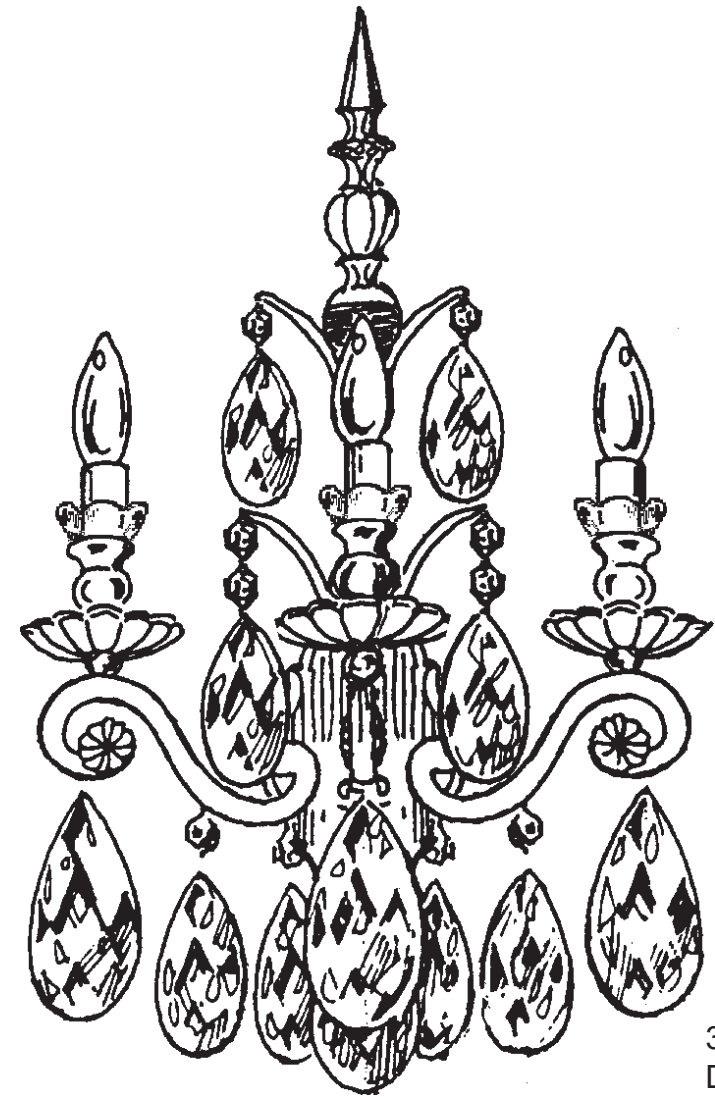











3 Lights  
Diameter: 15"  
Body Length: 22"  
Extension: 8"  
Hanging Weight: 8 lbs.

THIS DESIGN IS THE PROPRIETARY TRADE DRESS/TRADEMARK OF W SCHONBEK LLC.

 **SCHONBEK** | 1870

 **SCHONBEK** | 1870

								
MAX 60 W		110-120 V						

All electrical components must be installed by a licensed electrician in accordance with the National Electric Code and the appropriate local electrical codes.

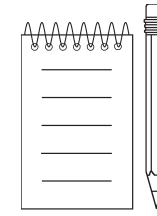
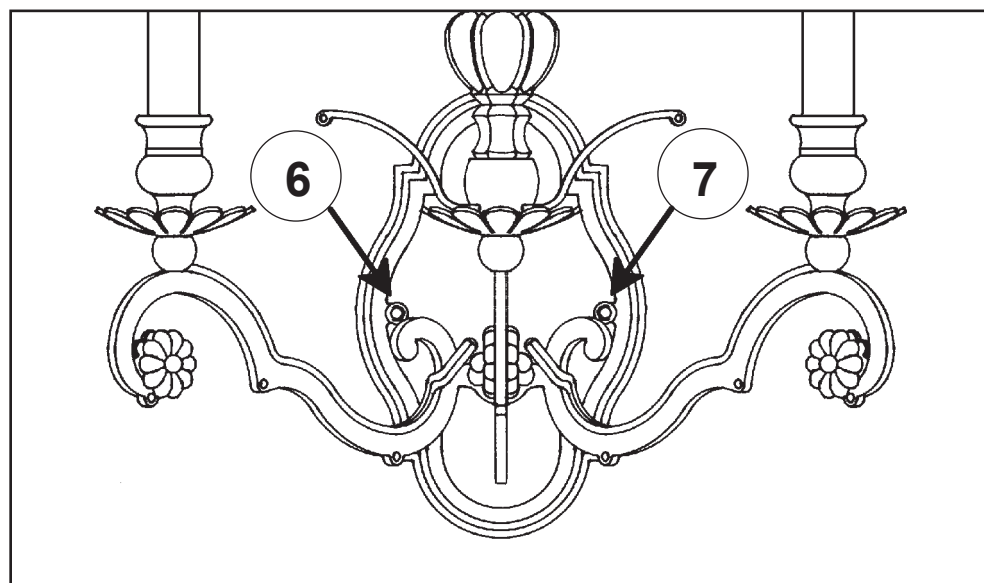
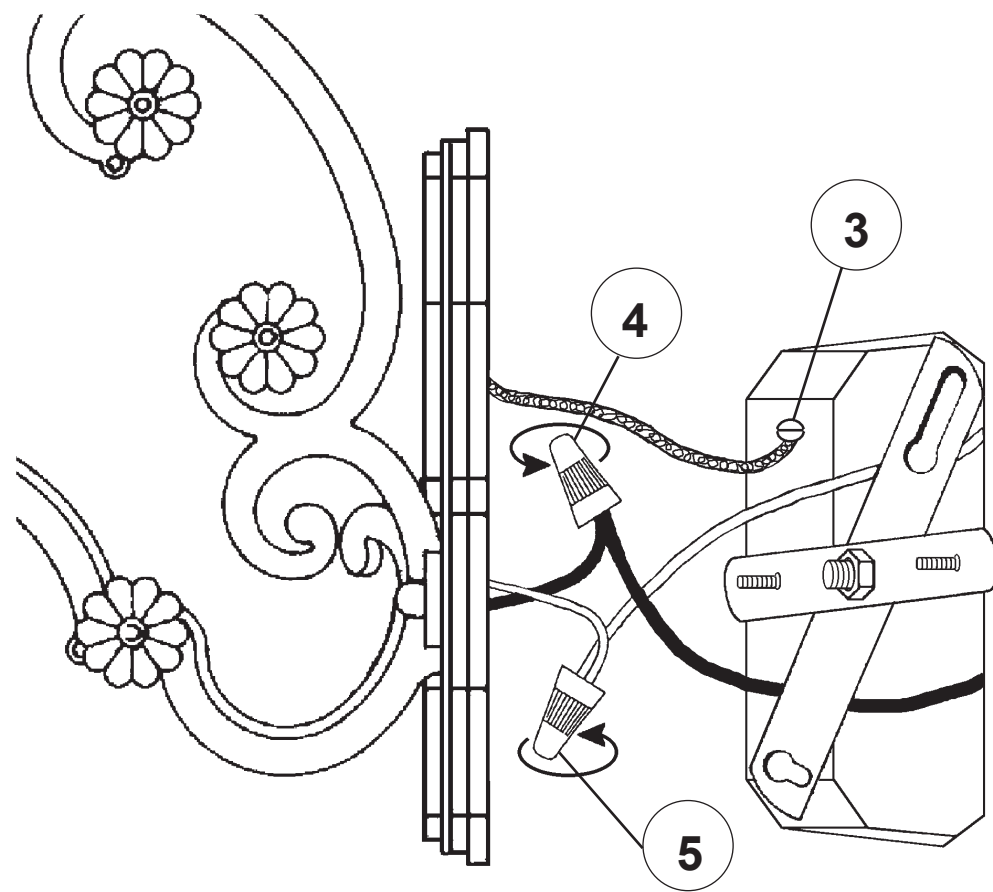
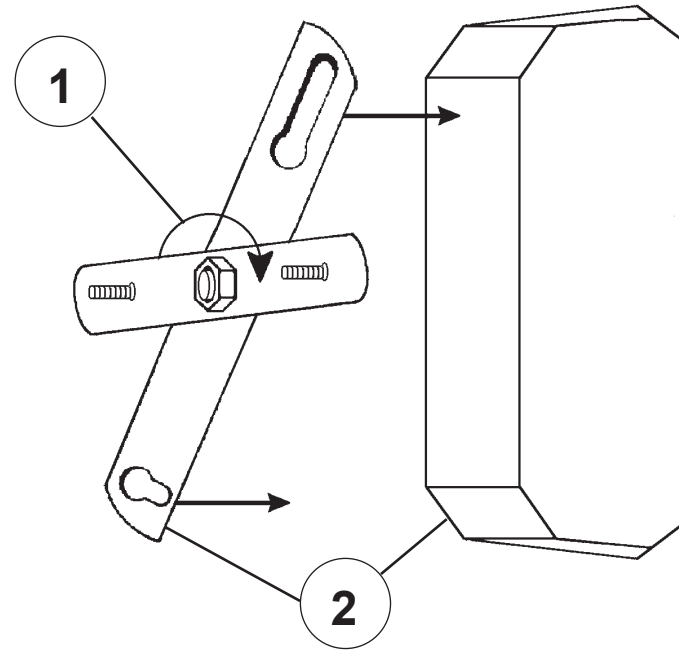

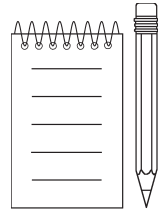

## SET 1

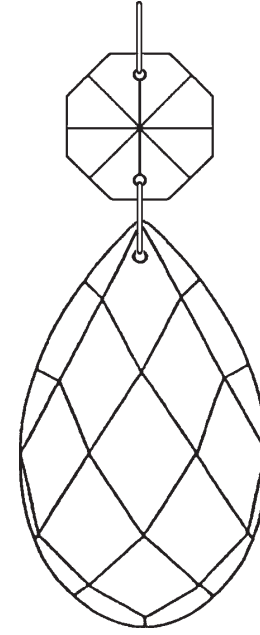

**N4003**  
2-1/2"  
63mm

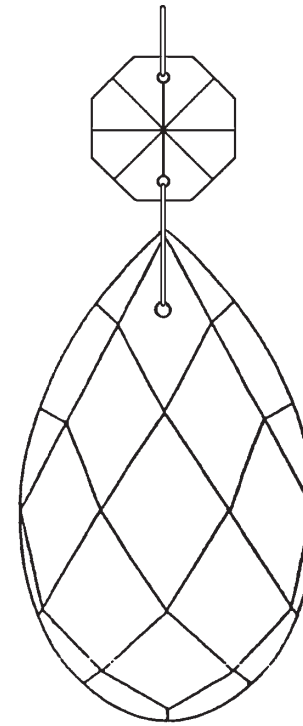

**N4000**  
3"  
76mm

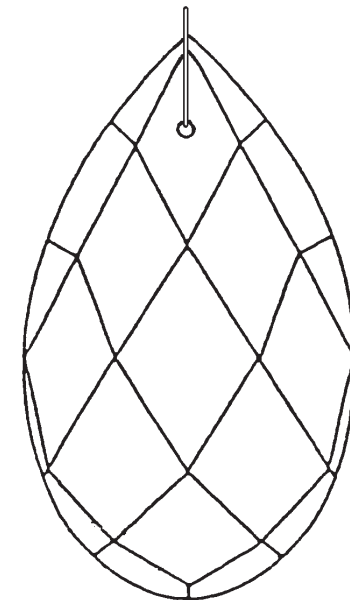

**N4001**  
3-1/2"  
89mm

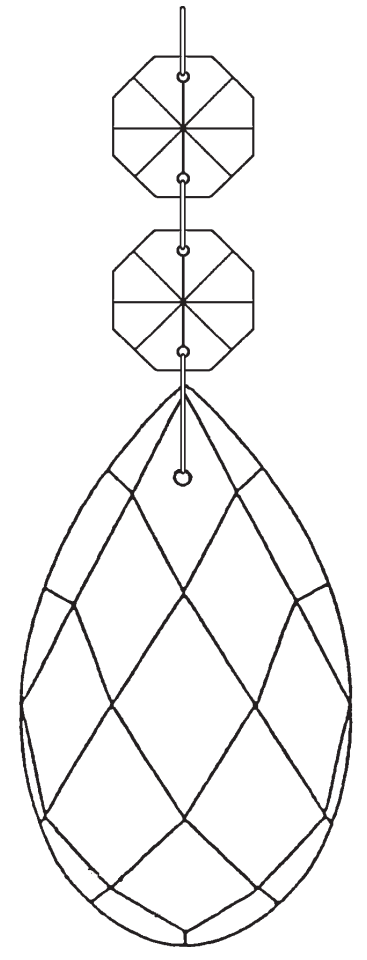

**N4002**  
3-1/2"  
89mm

## SET 2

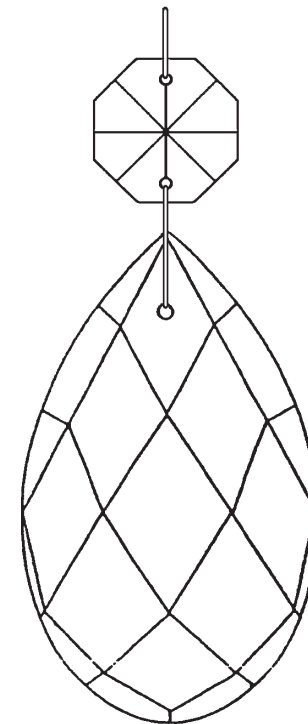

**N4000**  
3"  
76mm

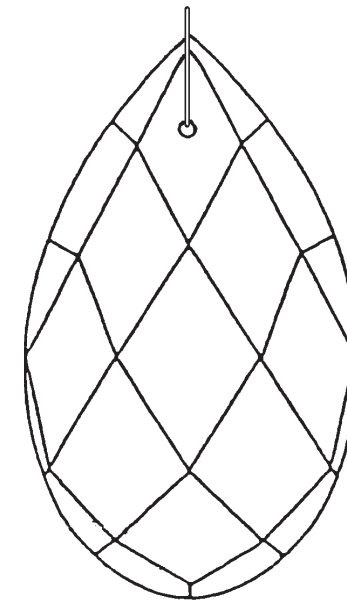

**N4001**  
3-1/2"  
89mm

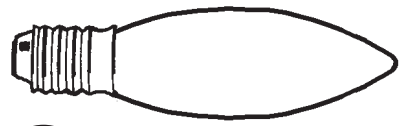

**9** 3 - B10  
60 Watts Max  
25 Watts Recommend

**Crystal Set 1 in Black**

**10**

9551/150/1

**8**

90002

**13**

N4003

**11**

N4000

**12**

N4000

**14**

N4002

**15**

N4002

**16**

N4002

**17**

N4001

**Crystal Set 2 in Black**

**20**

N4001

**20**

N4001

**19**

N4000

**18**

N4000

**18**

N4000

**19**

N4000



RENAISSANCE 3762- \_\_\_\_\_

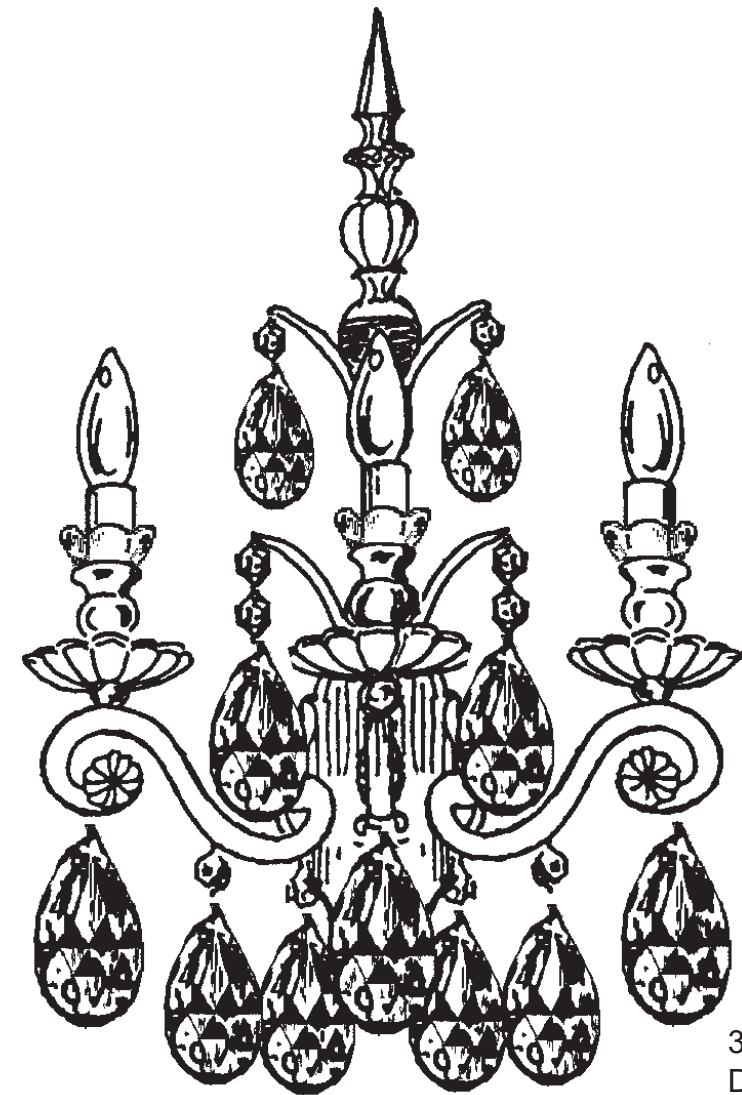











3 Lights  
Diameter: 15"  
Body Length: 22"  
Extension: 8"  
Hanging Weight: 8 lbs.

**T**HIS DESIGN IS THE PROPRIETARY  
TRADE DRESS/TRADEMARK OF  
W SCHONBEK LLC.

 **SCHONBEK** | 1870

 **SCHONBEK** | 1870

								
MAX <b>60</b> W		110-120 V						

All electrical components must be installed by a licensed electrician in accordance with the National Electric Code and the appropriate local electrical codes.

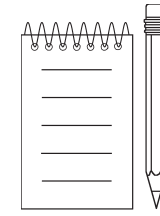
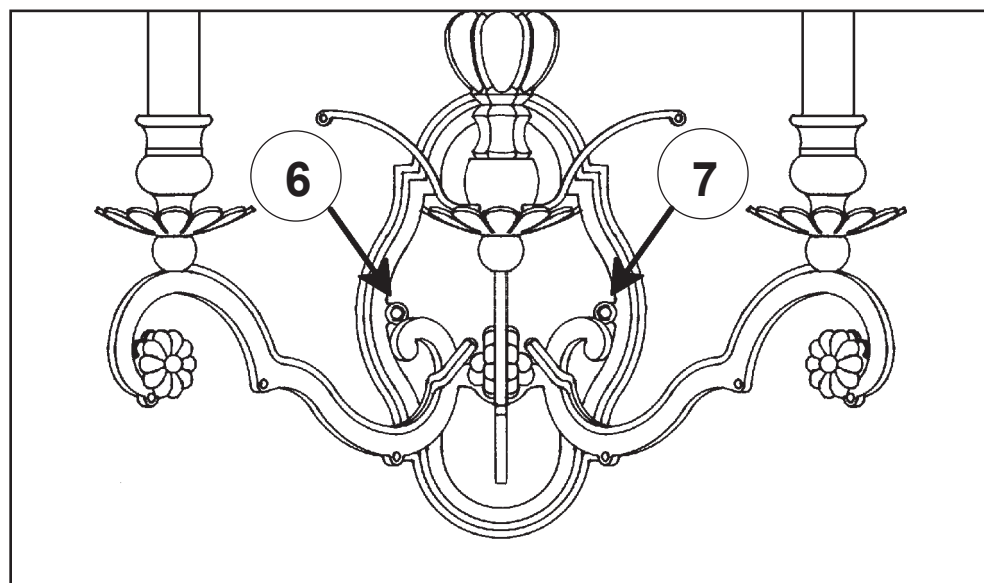
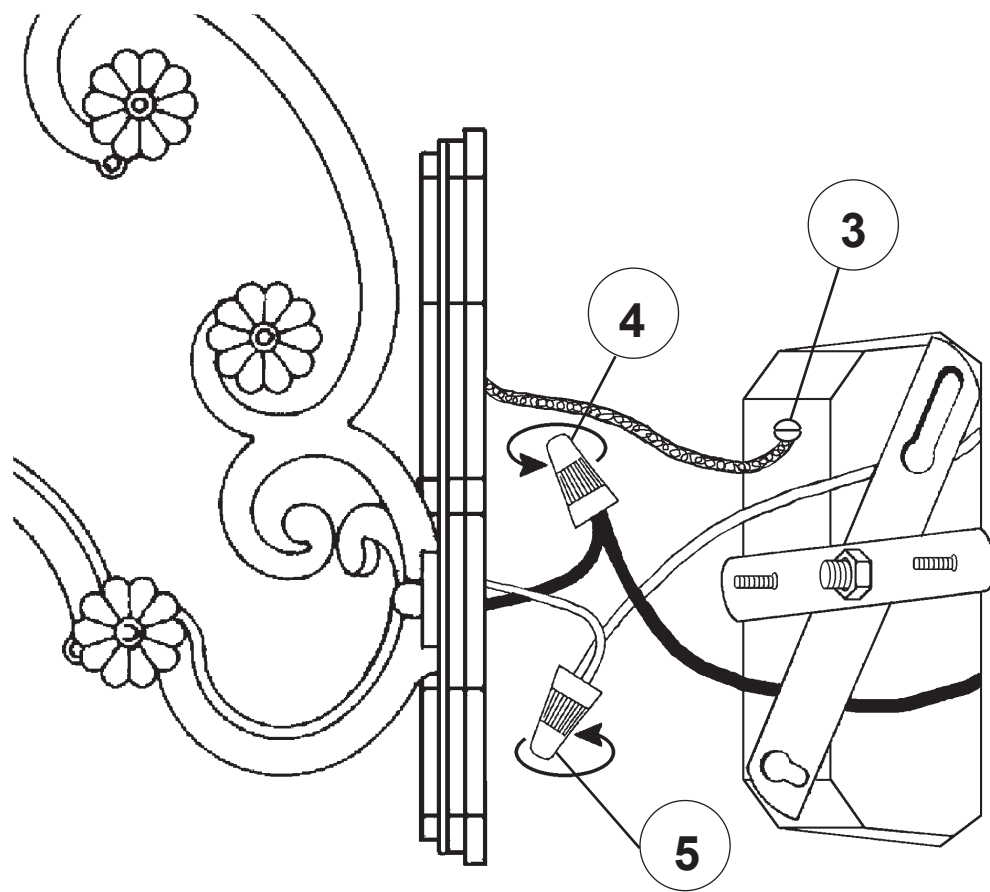
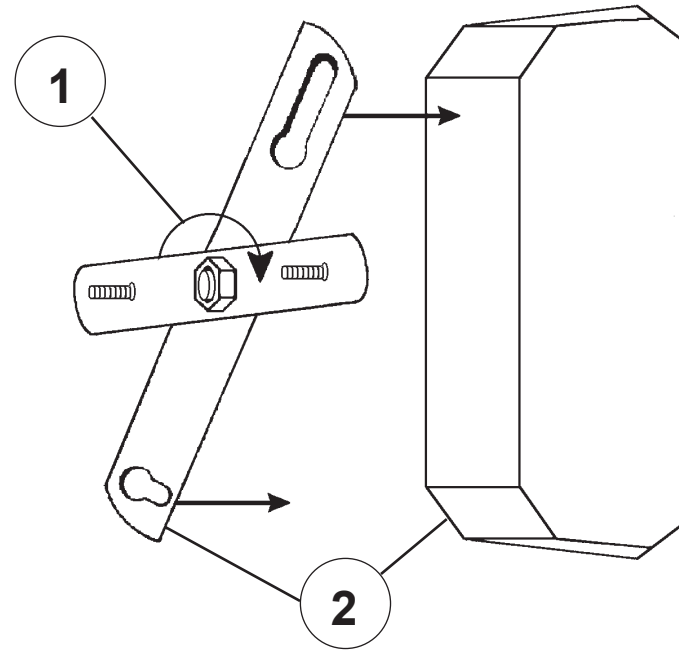

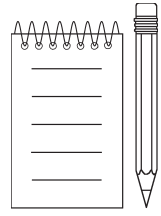

# SET 1

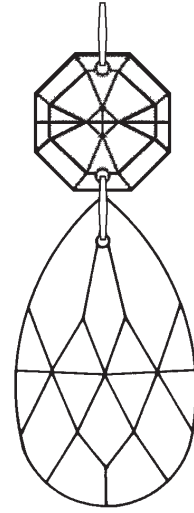

**N4044-\*\***  
2"  
50mm

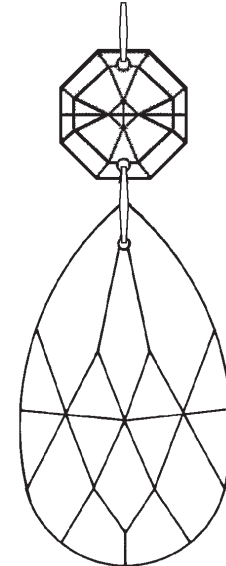

**N4003-\*\***  
2-1/2"  
63mm

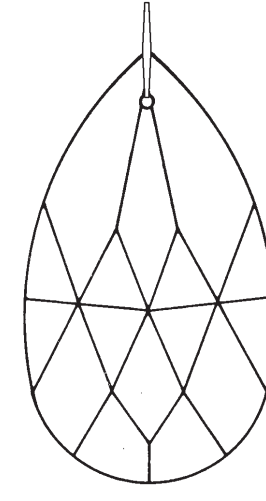

**N4004-\*\***  
3"  
76mm

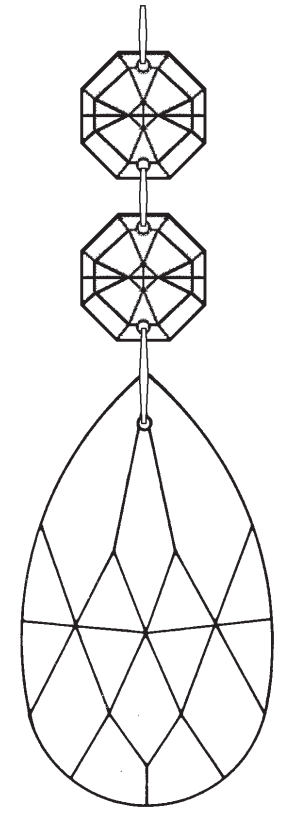

**N4010-\*\***  
3"  
76mm

# SET 2

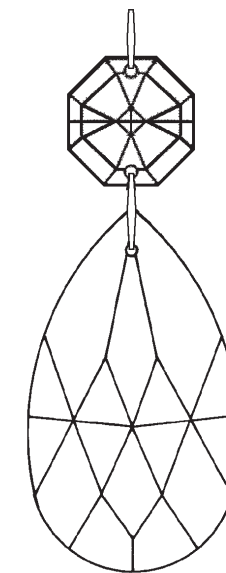

**N4003-\*\***  
2-1/2"  
63mm

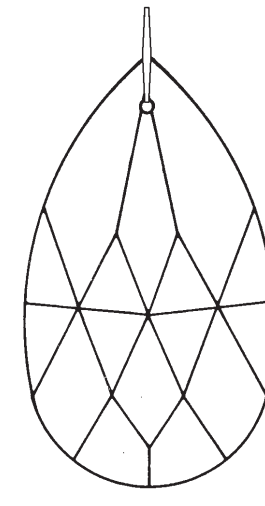

**N4004-\*\***  
3"  
76mm



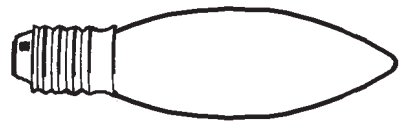

**9** 3 - B10  
60 Watts Max  
25 Watts Recommend

**Crystal Set 2 in Black**

**Crystal Set 1 in Black**

