

RENAISSANCE 3769- ____













THIS DESIGN IS THE PROPRIETARY TRADE DRESS/TRADEMARK OF W SCHONBEK LLC.

5 Lights
Diameter: 14-1/2"
Body Length: 19"
Hanging Weight: 10 lbs.

 **SCHONBEK** | 1870

 **SCHONBEK** | 1870

								
MAX 60 W	110-120 V							

All electrical components must be installed by a licensed electrician in accordance with the National Electric Code and the appropriate local electrical codes.

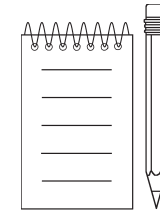
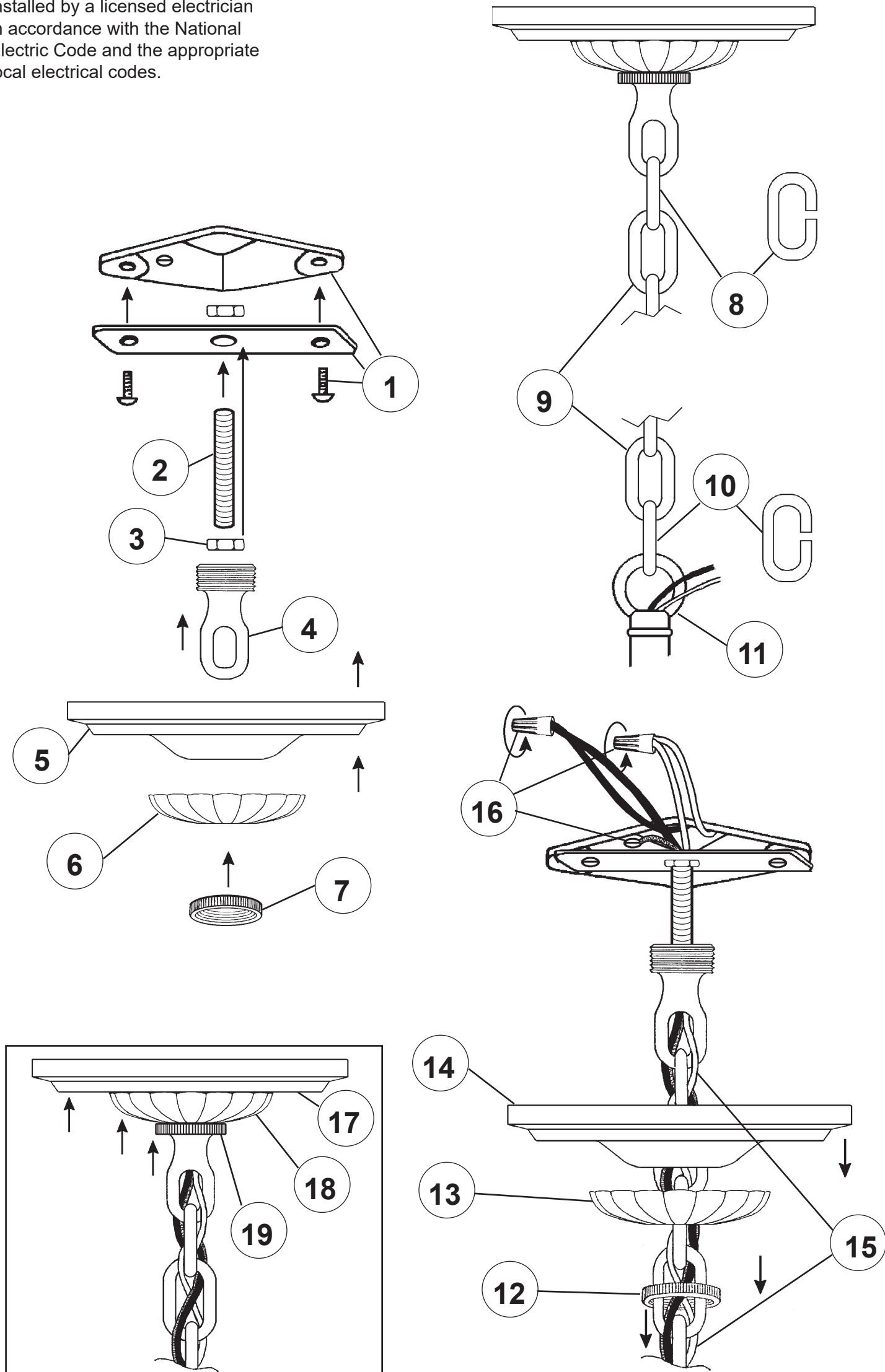

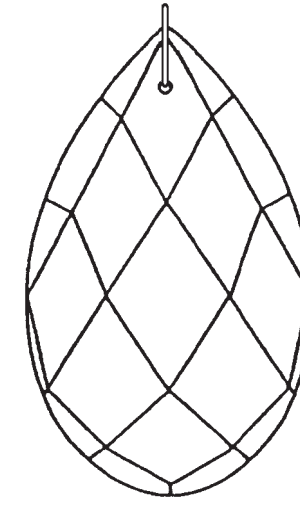

N4032
2-1/2"
63mm

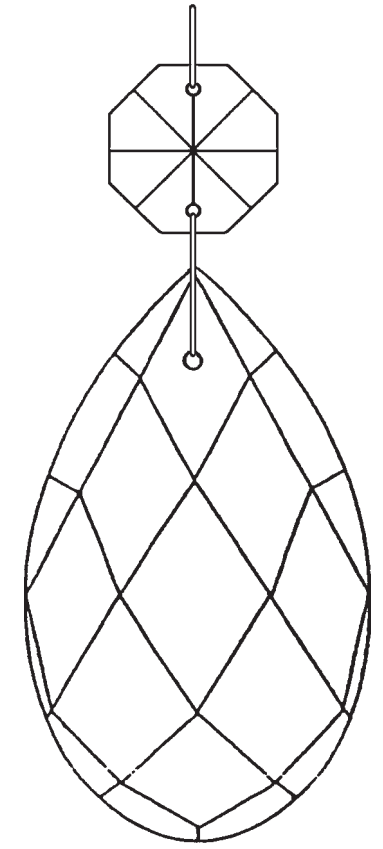

N4000
3"
76mm

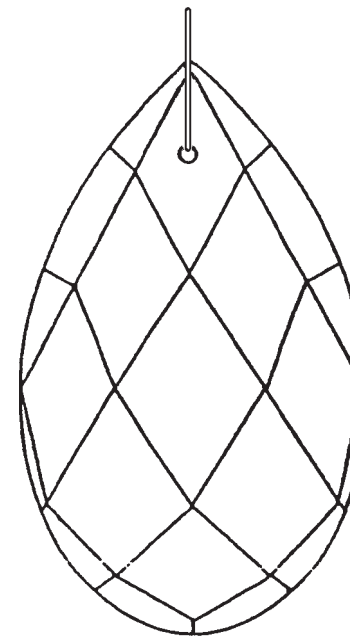

N4004
3"
76mm

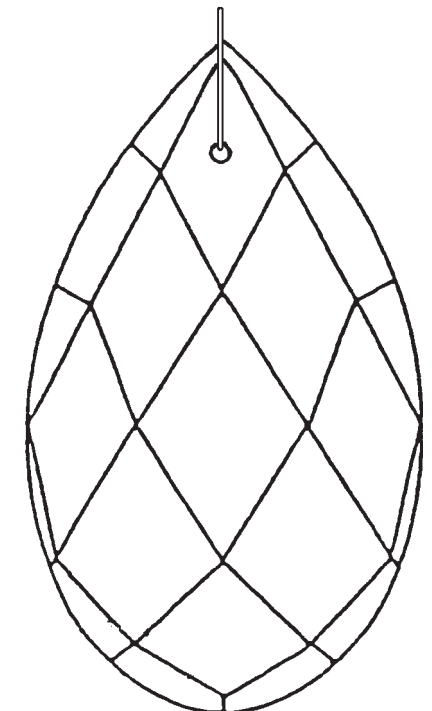

N4001
3-1/2"
89mm

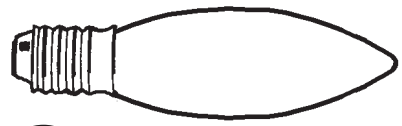

21 5 - B10
60 Watts Max
25 Watts Recommend

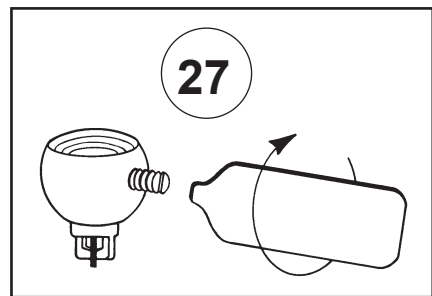
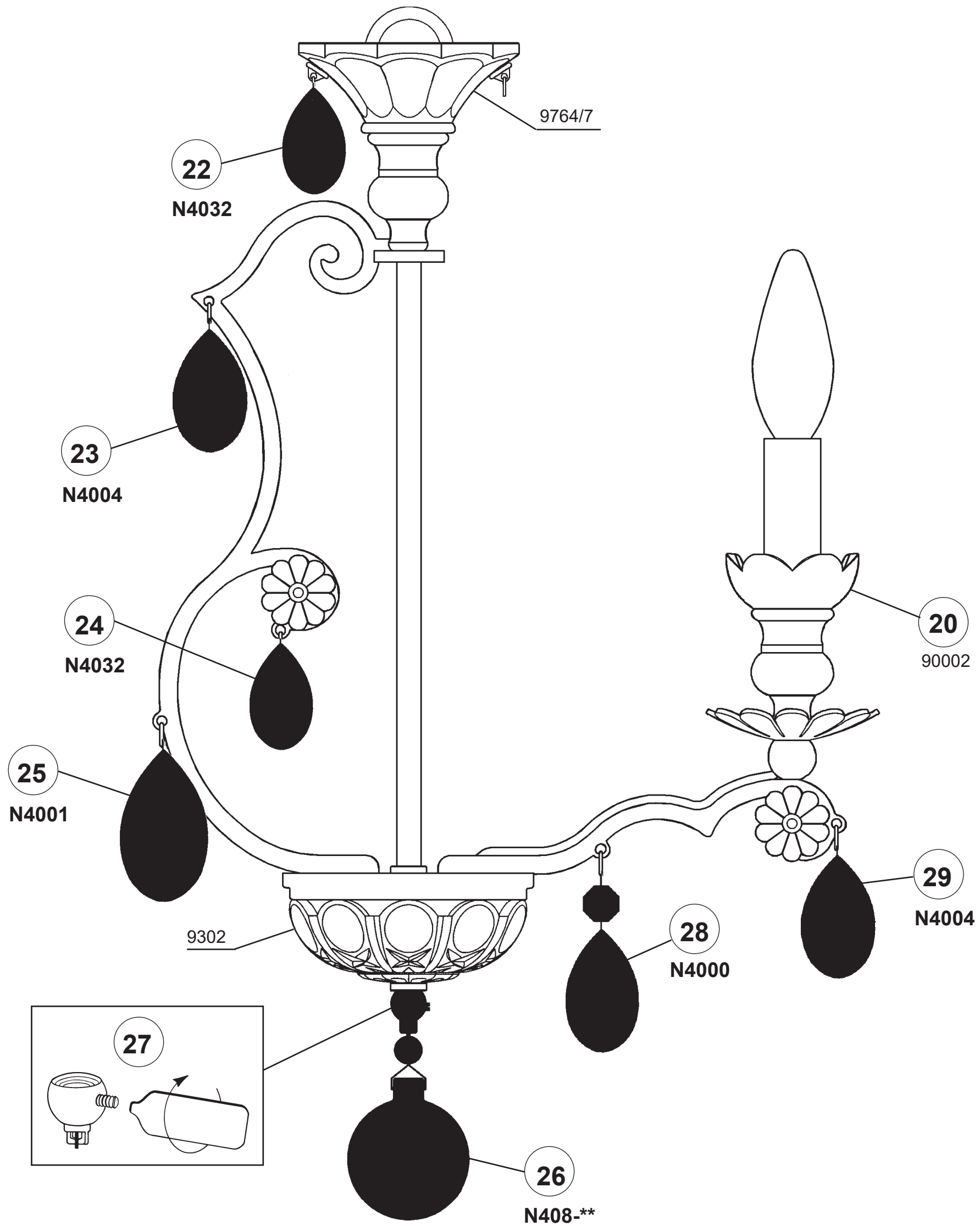

RENAISSANCE 3769- _____

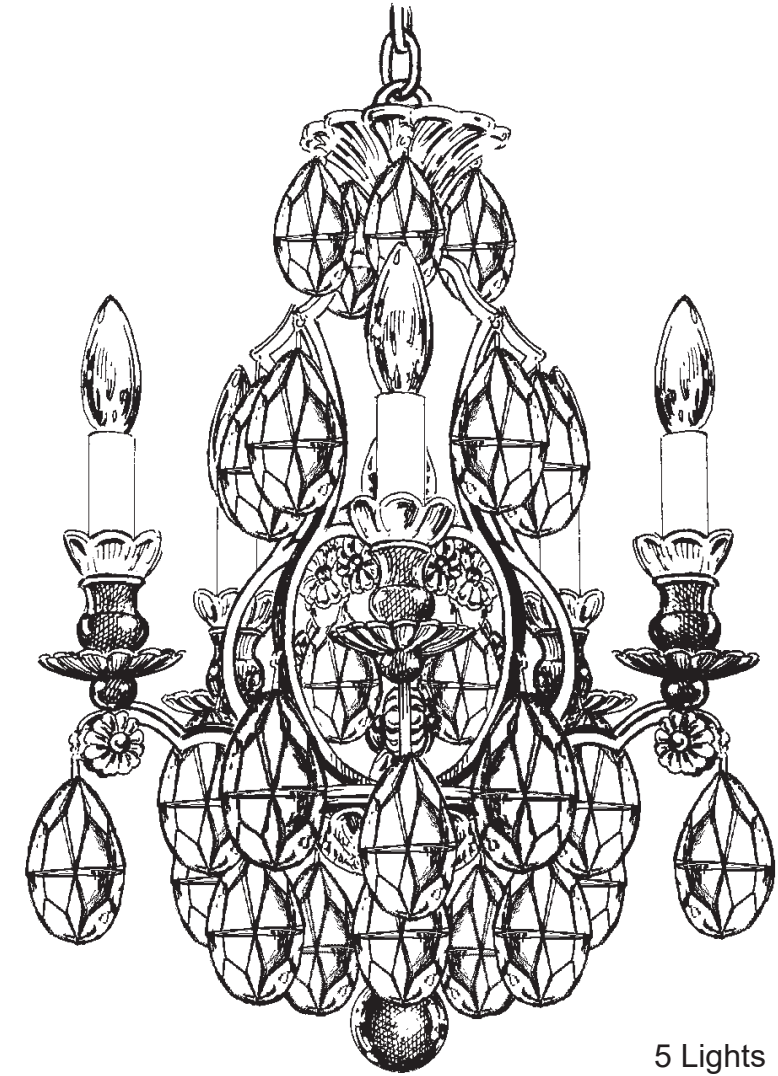











THIS DESIGN IS THE PROPRIETARY TRADE DRESS/TRADEMARK OF W SCHONBEK LLC.

5 Lights
Diameter: 14-1/2"
Body Length: 19"
Hanging Weight: 10 lbs.

 **SCHONBEK** | 1870

 **SCHONBEK** | 1870

								
MAX 60 W	110-120 V							

All electrical components must be installed by a licensed electrician in accordance with the National Electric Code and the appropriate local electrical codes.

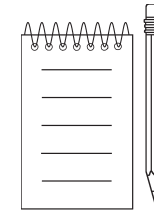
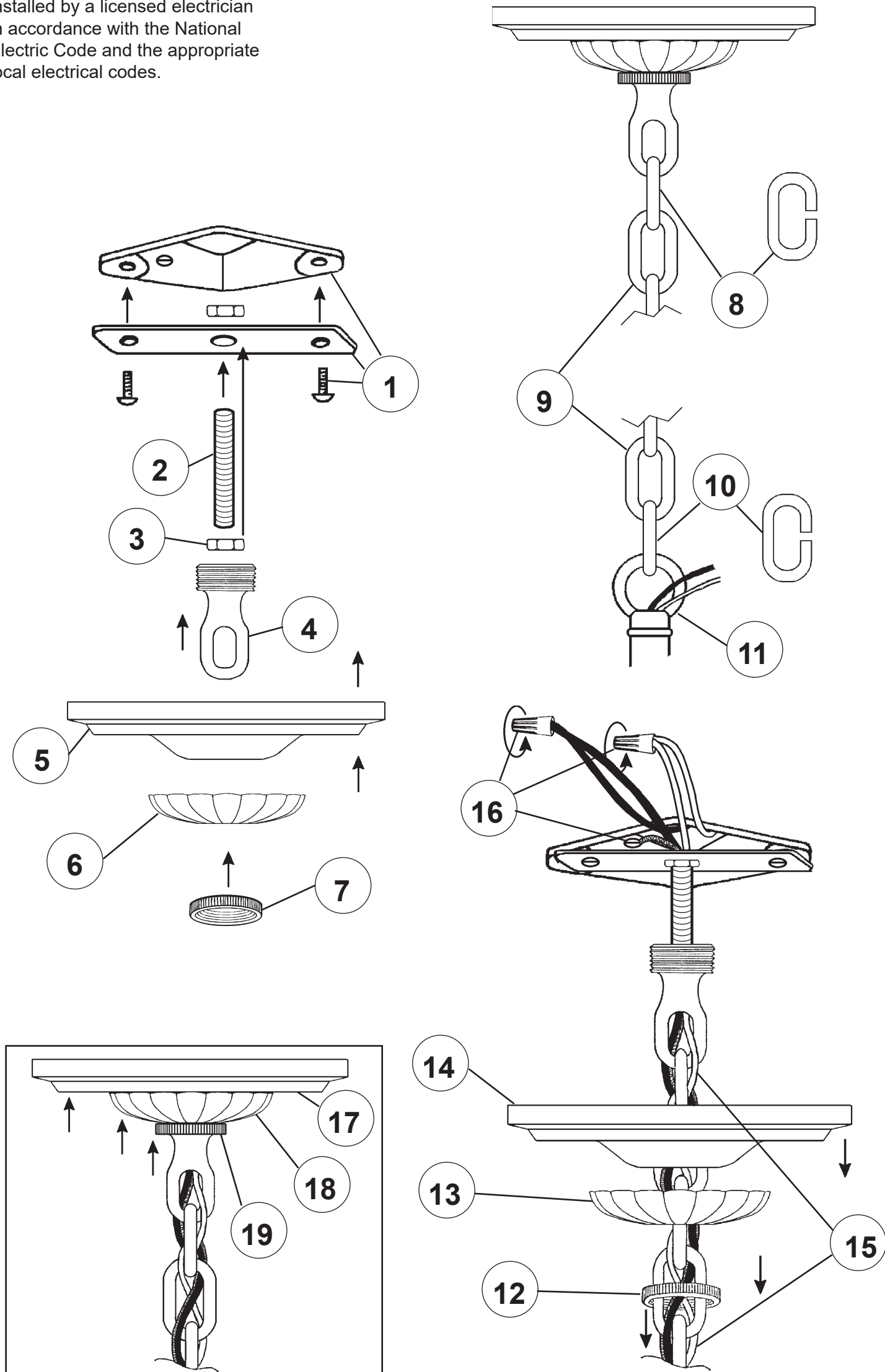

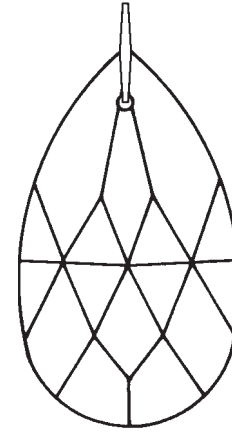
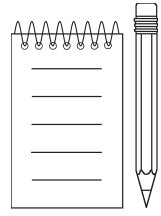

N2793-**
2"
50mm

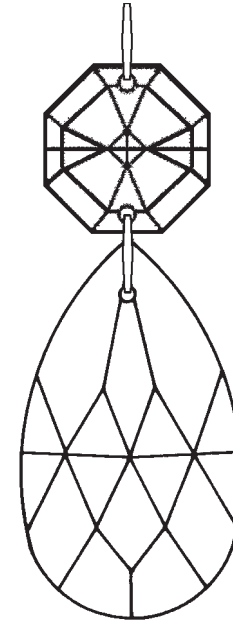

N4044-**
2"
50mm

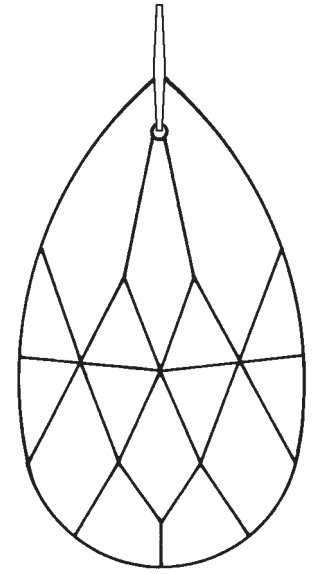

N4014-**
2-1/2"
63mm

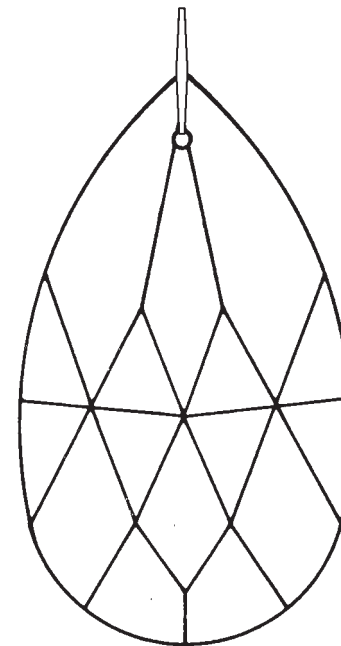

N4004-**
3"
76mm

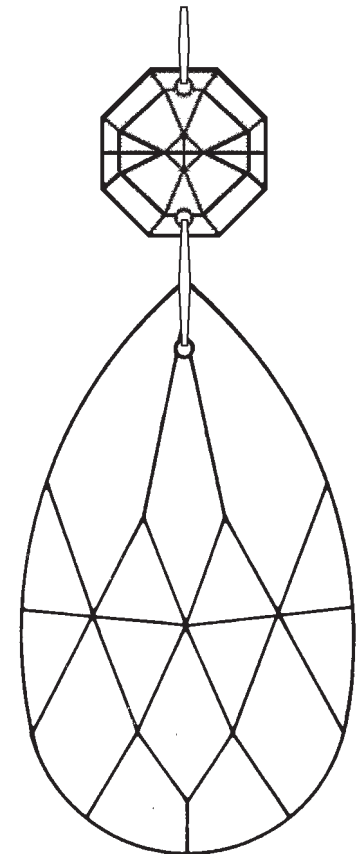

N4000-**
3"
76mm

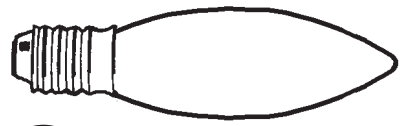

21 5 - B10
60 Watts Max
25 Watts Recommend

