

RENAISSANCE 3784- ____

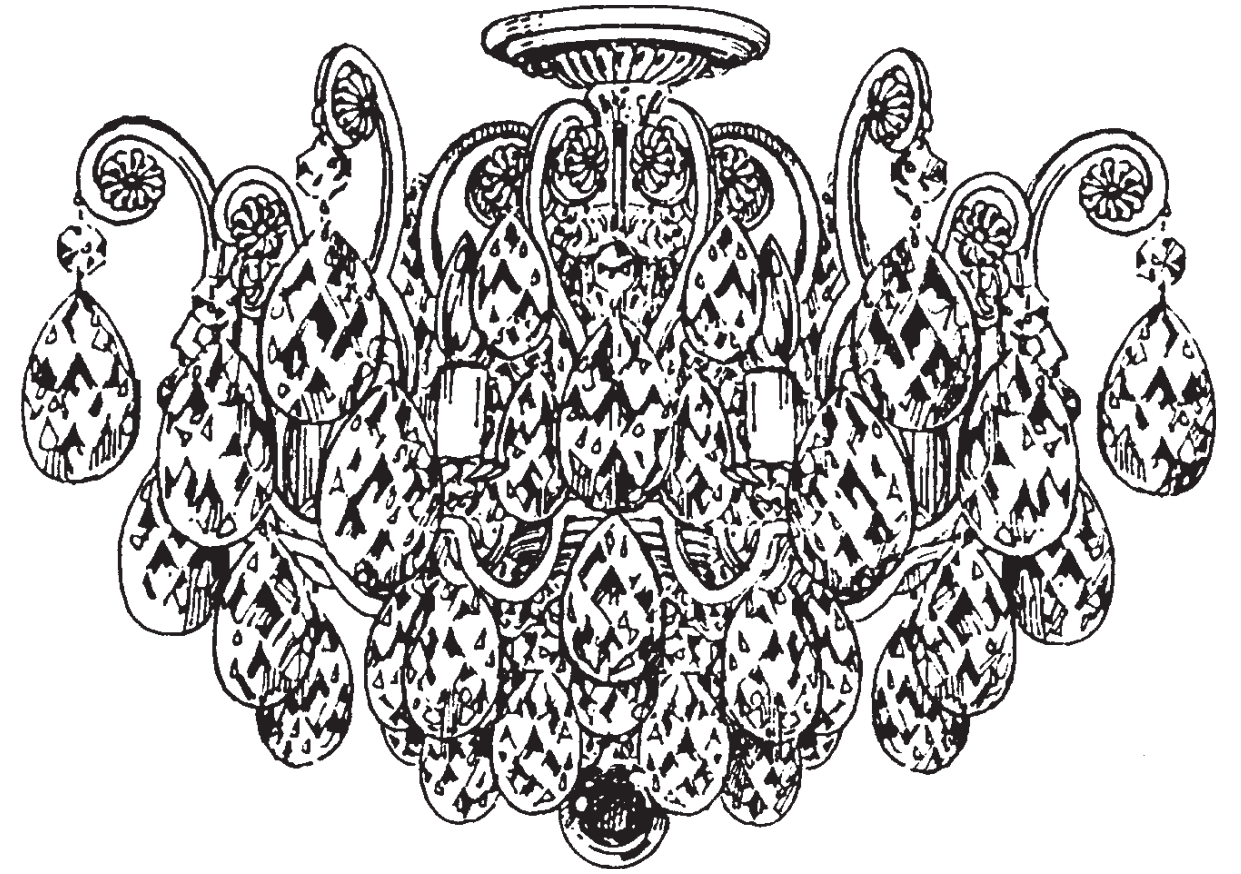











THIS DESIGN IS THE PROPRIETARY TRADE DRESS/TRADEMARK OF W SCHONBEK LLC.

6 Lights
Diameter: 20"
Body Length: 15"
Hanging Weight: 18 lbs.

 **SCHONBEK** | 1870

 **SCHONBEK** | 1870

								
MAX 40 W	110-120 V							

All electrical components must be installed by a licensed electrician in accordance with the National Electric Code and the appropriate local electrical codes.

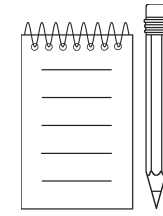
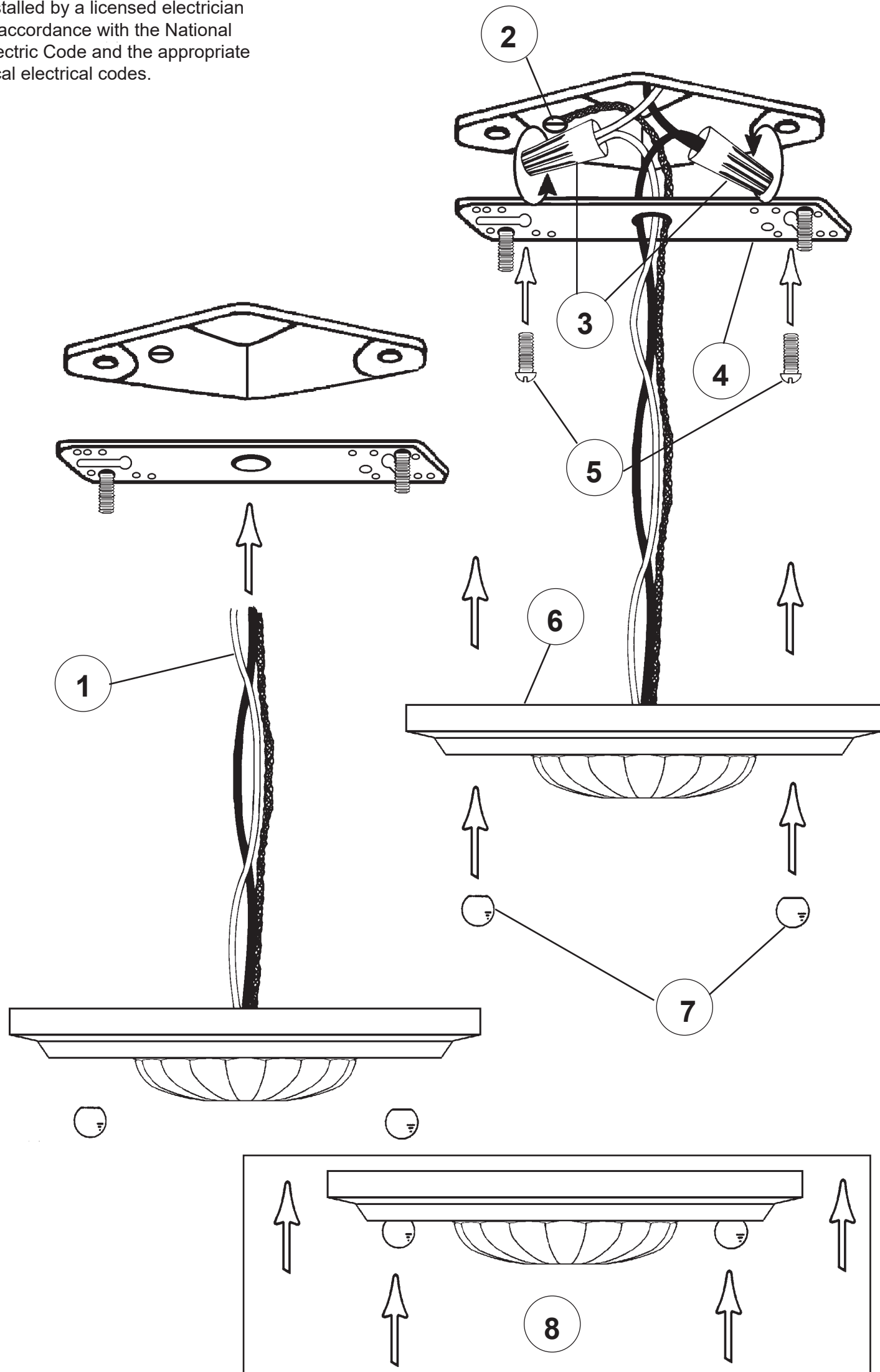

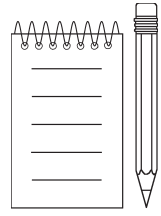

SET 1

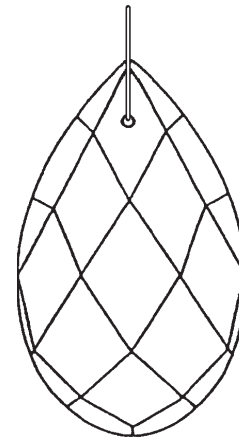

N4014
2-1/2"
63mm

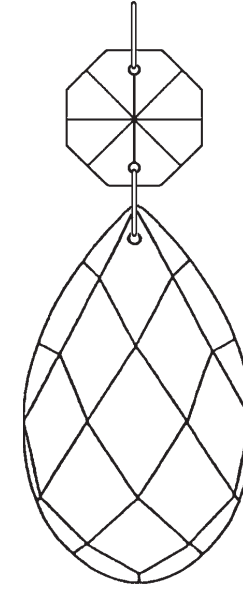

N4003
2-1/2"
63mm

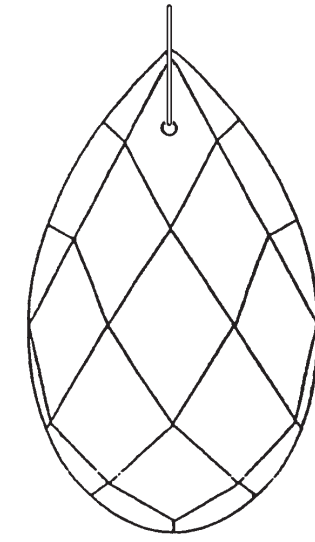

N4004
3"
76mm

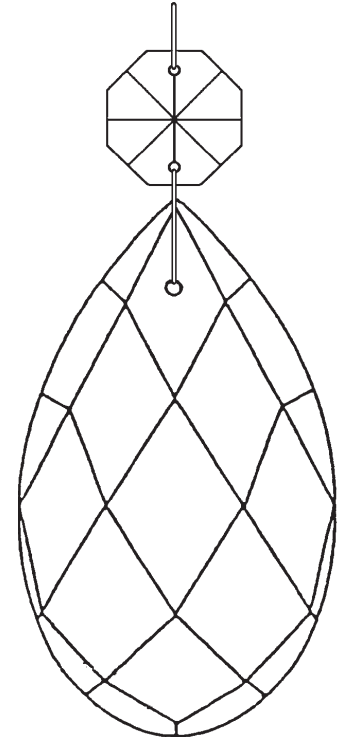

N4007
3-1/2"
89mm

SET 2

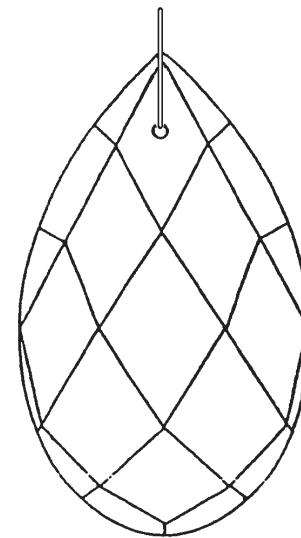

N4004
3"
76mm

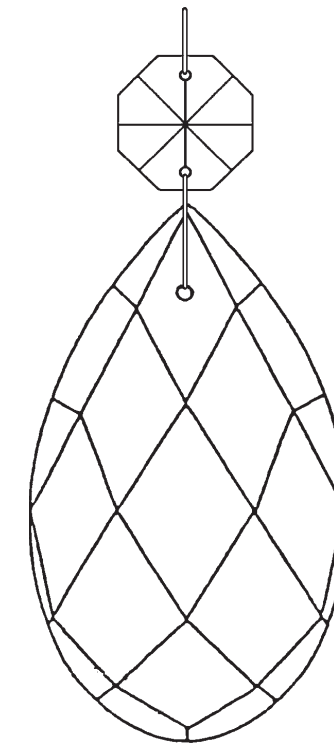

N4007
3-1/2"
89mm

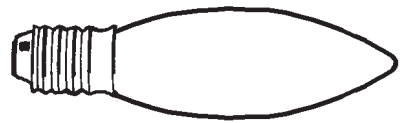

9 6 - B10
40 Watts Max
25 Watts Recommend

Crystal Set 1 in Black

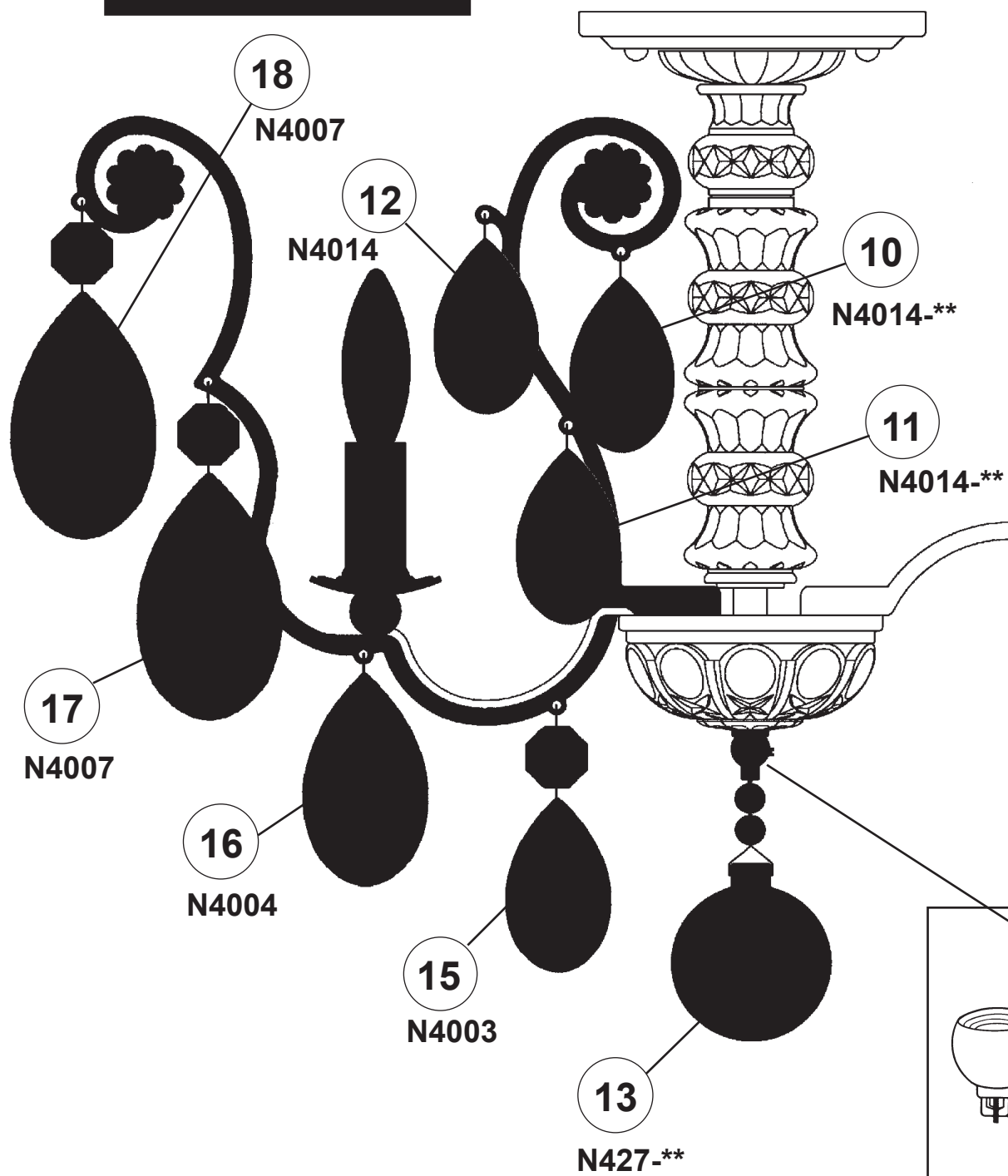

Crystal Set 2 in Black

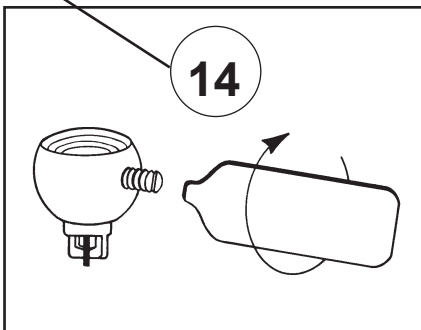
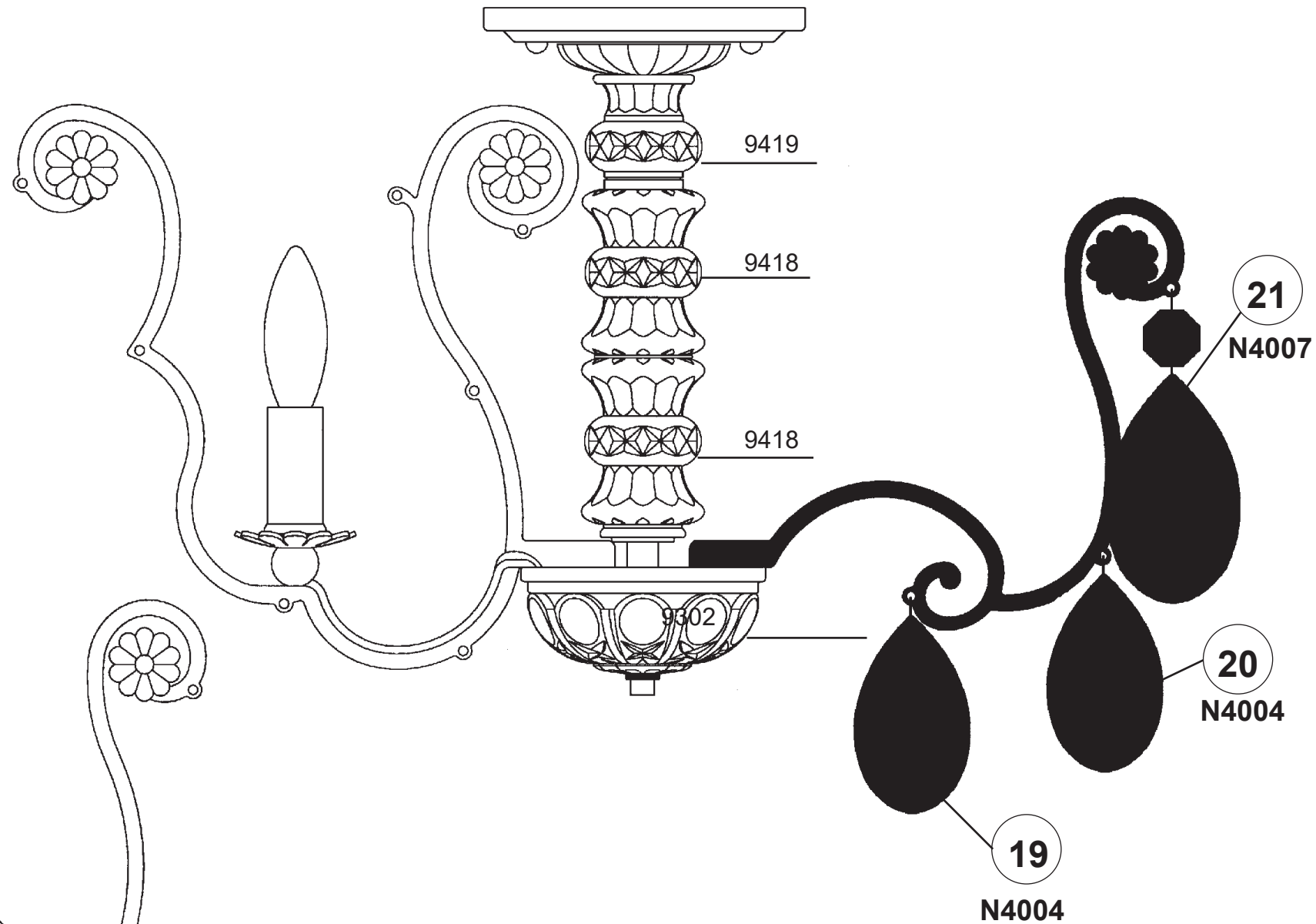

RENAISSANCE 3784- _____

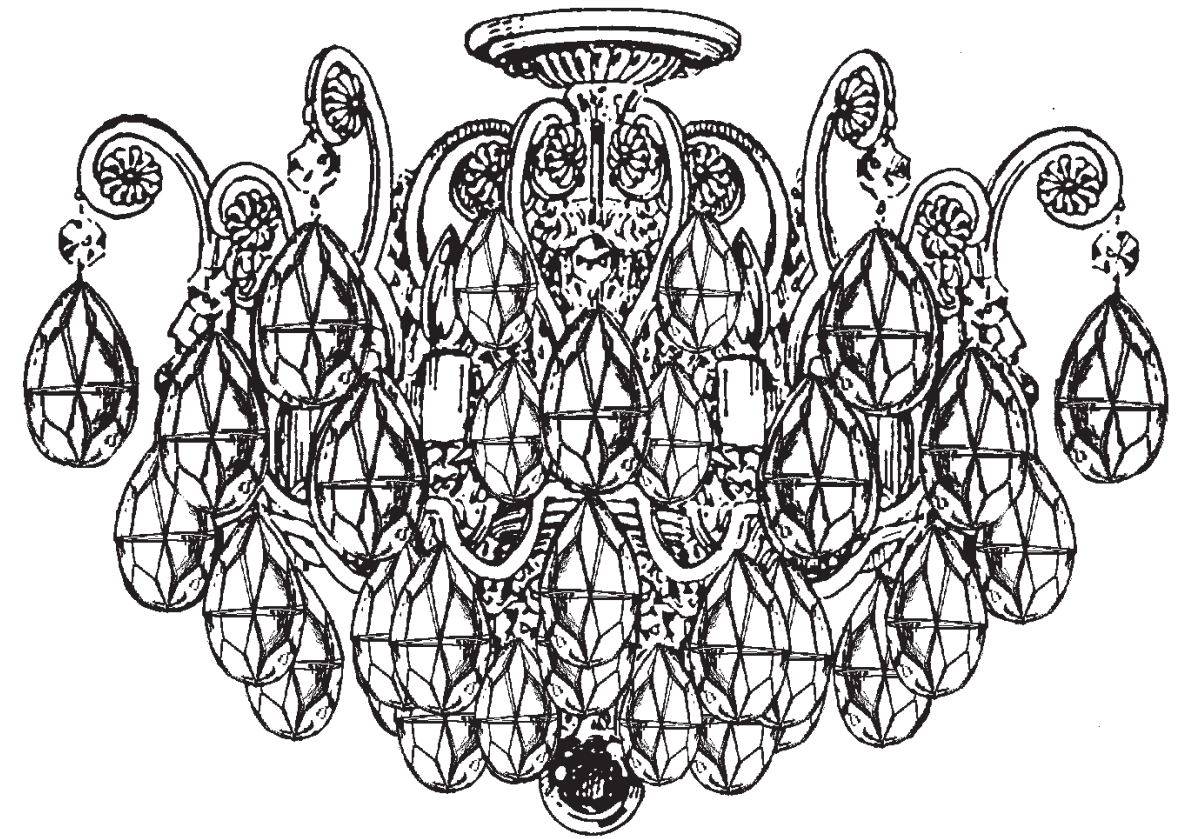











6 Lights
Diameter: 20"
Body Length: 15"
Hanging Weight: 18 lbs.

THIS DESIGN IS THE PROPRIETARY TRADE DRESS/TRADEMARK OF W SCHONBEK LLC.

 **SCHONBEK** | 1870

 **SCHONBEK** | 1870

								
MAX 40 W	110-120 V							

All electrical components must be installed by a licensed electrician in accordance with the National Electric Code and the appropriate local electrical codes.

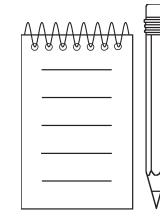
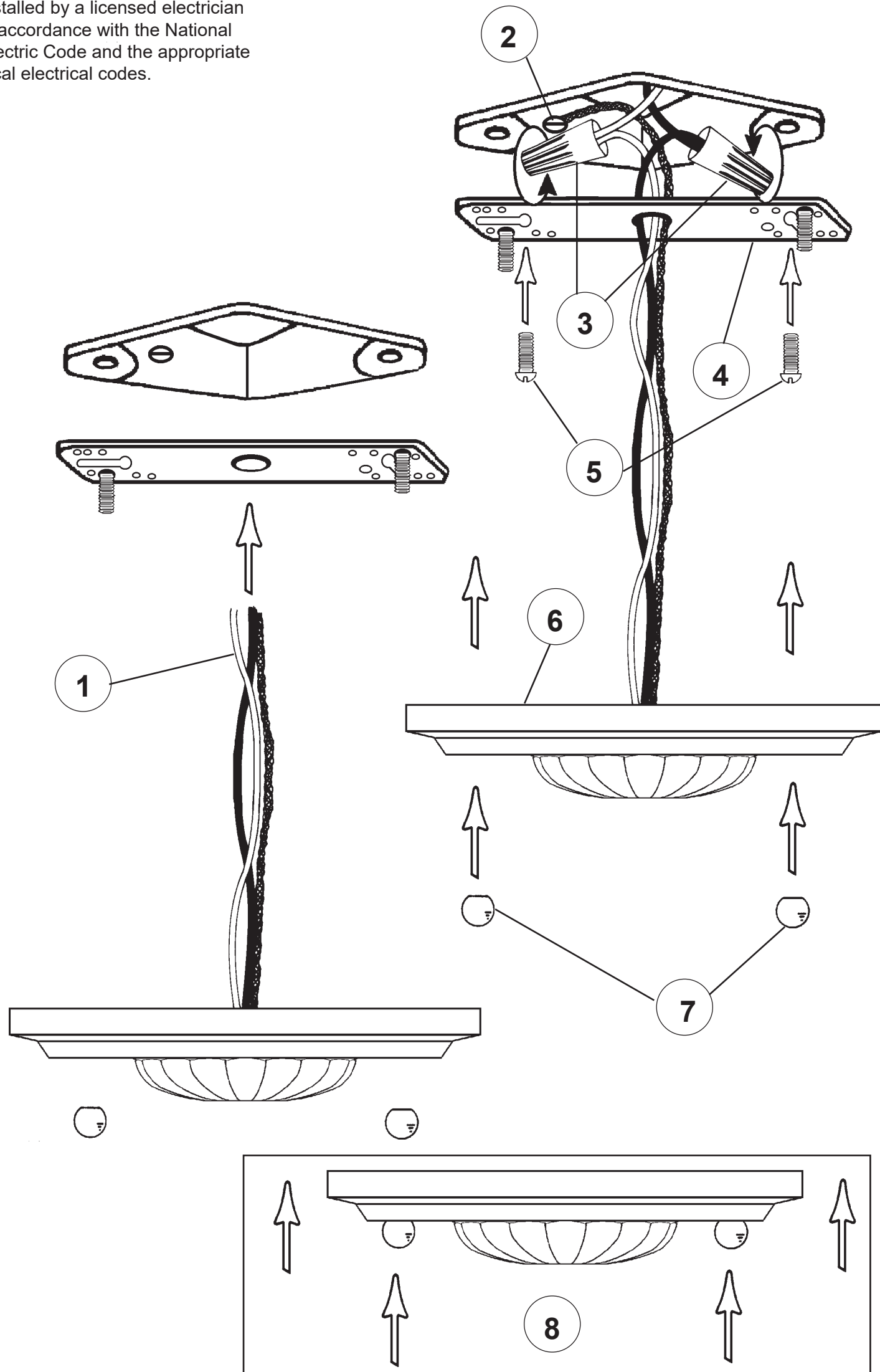

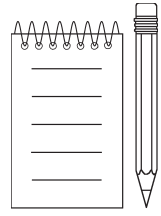

SET 1

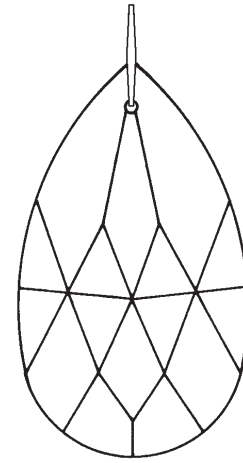

N4014-**
2-1/2"
63mm

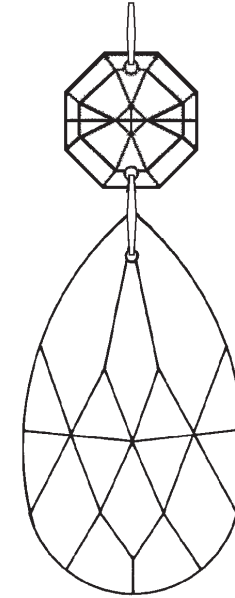

N4003-**
2-1/2"
63mm

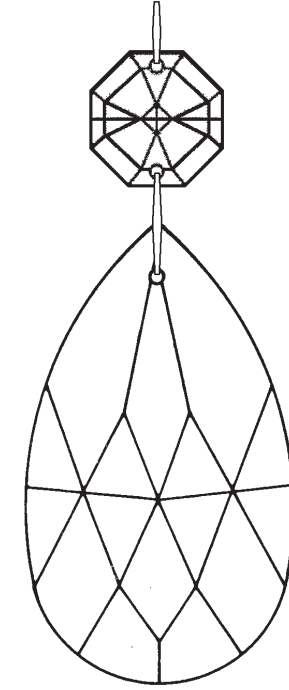

N4000-**
3"
76mm

SET 2

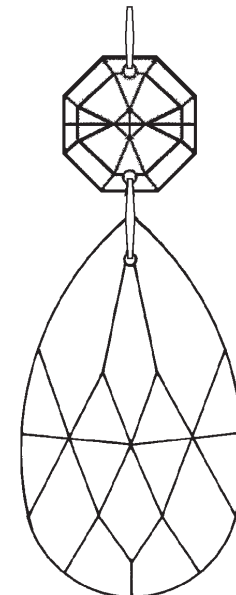

N4003-**
2-1/2"
63mm

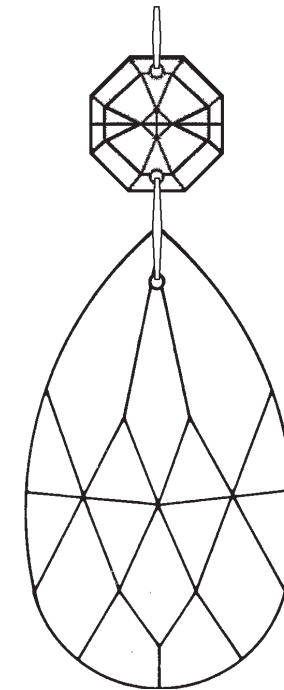

N4000-**
3"
76mm

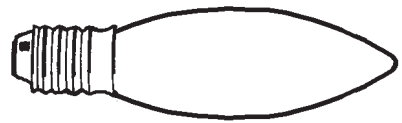

9 6 - B10
40 Watts Max
25 Watts Recommend

Crystal Set 2 in Black

Crystal Set 1 in Black

