

# PLAZA 66730 TRIM DIAGRAM

## Instructions for electrician STEP 2

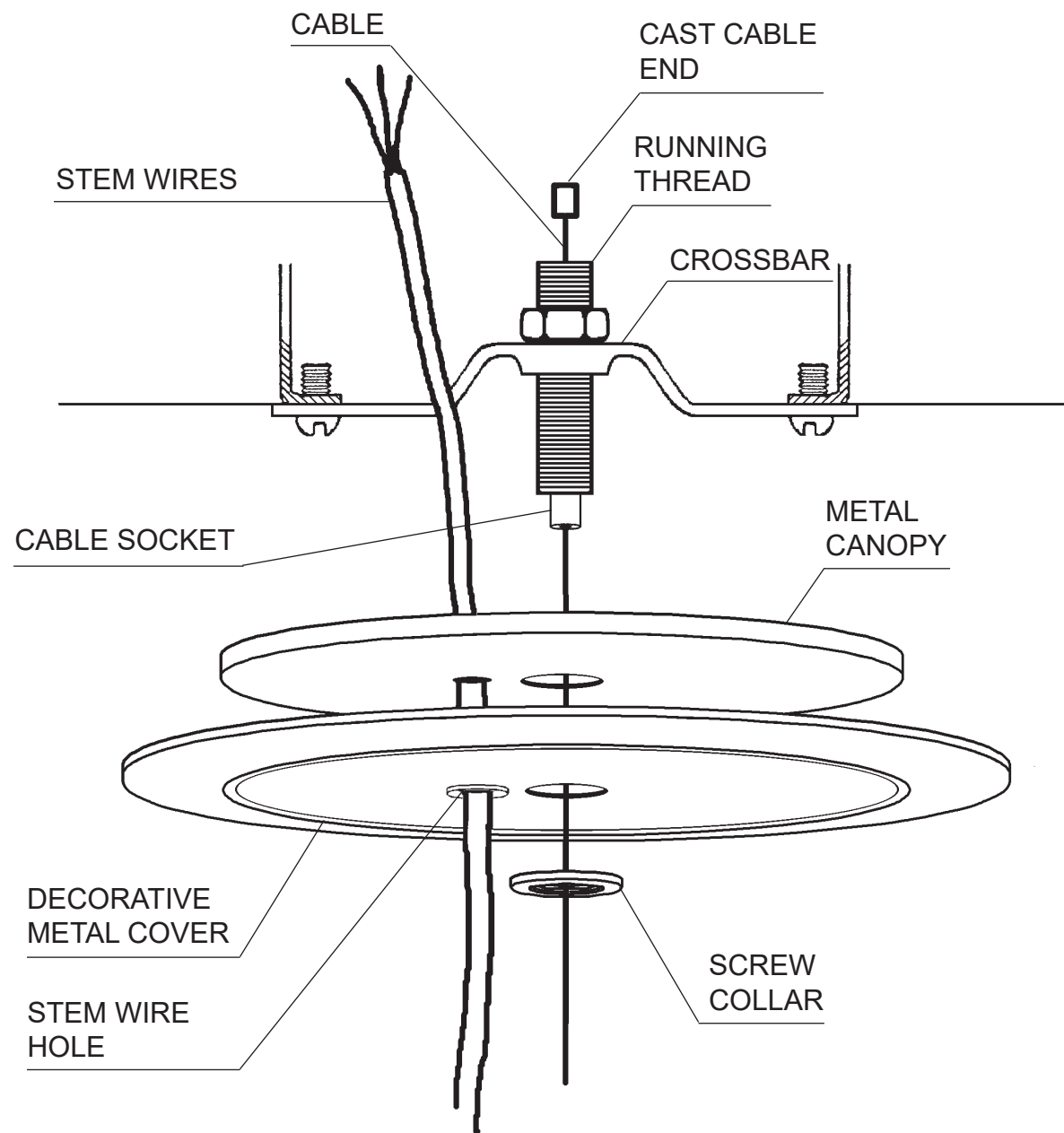

**2** Remove the screw collar, decorative metal cover, metal canopy from the canopy assembly and attach crossbar using hardware (not provided) to outlet box. Feed suspension cable through running thread from the top so that the cast cable end is seated in the inside of the cable socket. Attach crossbar to the ceiling with cable hanging down. Feed suspension cable through the center hole (larger hole) of the metal canopy, decorative metal cover and then screw collar. The metal canopy must be on top of the decorative metal cover. Feed cable into cable glider on chandelier frame and hang to desired height. Loosen the safety nut on the cable glider by turning counter clockwise. Slide cable into glider and allow it to play out of the side of the cable glider temporarily. To adjust height loosen the safety nut and depress it until the cable is released to move the frame up and down the cable. Feed stem wire through the screw collar, stem wire hole, decorative metal cover and metal canopy (the smaller hole). When chandelier is at desired height, trim stem wire and connect ground wire (marked with green tracer) and power wires (black or white tracers) in outlet box. Raise metal canopy and decorative metal cover to ceiling and secure to running thread with the screw collar. Supplied are 4 cable grips. Adjust along stem wire and clip to support cable as desired. Cut suspension cable with cable cutters leaving about 1/2" protruding from the side of the cable glider.



22 Lights  
Diameter: 21"  
Height: 19"  
Hanging Weight: 24 lbs.

THIS DESIGN IS THE PROPRIETARY TRADE DRESS/TRADEMARK OF W SCHONBEK LLC.



**See diagram on back page  
Follow steps in exact order  
Save this trim diagram for future reference**

**1** **IMPORTANT**  
*Person who opens carton should record the following information for future service.*

CODE #	_____	Four-digit number on outside of carton.
PACKER #	_____	See crystal package label.
ORDER #	_____	See crystal package label.



# Instructions for crystal trimming

## STEPS 3 - 8

**3** 

You will need 21 - B8  
40 Watts Max  
25 Watts recommended  
(Supplied - Schonbek #: 30025)

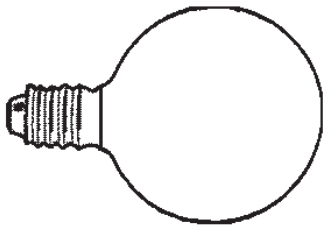

You will need 1 - G16-1/2  
40 Watts Max  
25 Watts recommended  
(Supplied - Schonbek #: 30764)

**Install bulbs and be sure to test fixture BEFORE trimming.**

**4** Install three bottom crystal grids with eleven thumb nuts (already screwed onto grids) to bottom of Rings #1, #3 and #5.

**5** Screw ball "D" onto bottom of grid 87/315/1SO. Tighten set screw to lock into position (Diagram #1).

**6** Hang chain "A" first into Ring #8. Hold chain by the top square crystal. (NOTE: Flat side of large crystals face out!) Insert square crystal into the pocket of the ring. (Diagram #2) Lower the chain until the top square stone seats itself into the ring pocket. When top ring is completely trimmed, hang chain "A" into ring #7.

**7** Starting with ring #2, hang chain "B" by placing the connector in the hole on the ring. (NOTE: FLAT SIDE OF LARGE CRYSTALS FACE OUT!!) When the bottom ring is completely trimmed hang chain "B" into ring #4.

**8** Hang chain "C" into ring #6. Hold chain by the top square crystal. (NOTE: FLAT SIDE OF LARGE CRYSTALS FACE OUT AND CHAINS ARE SYMMETRICAL SO EITHER END WILL WORK.) Insert square crystal into the pocket of the ring. (Diagram #2) Lower the chain until the top square stone seats itself into the ring pocket.

**DIAGRAM #2**

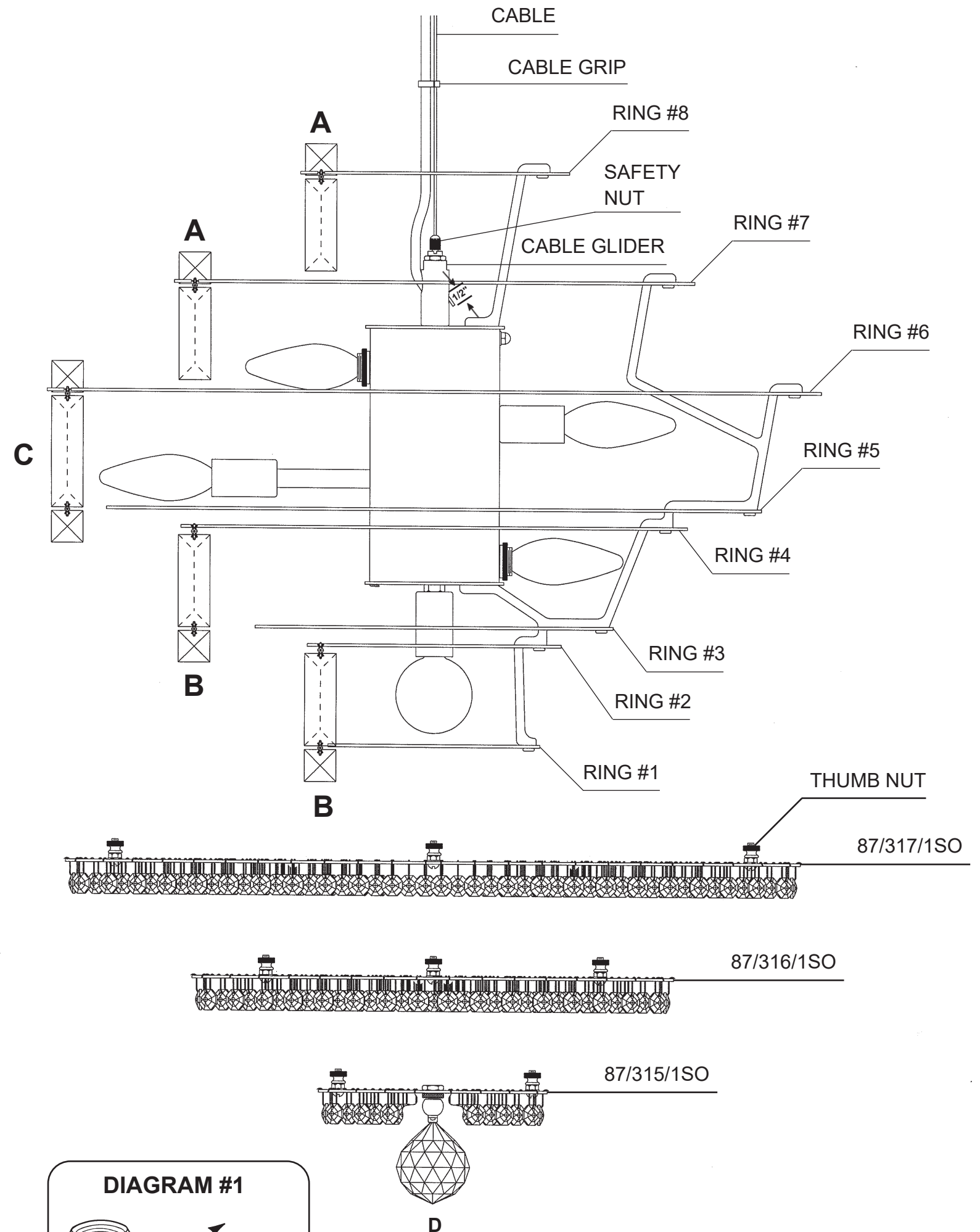
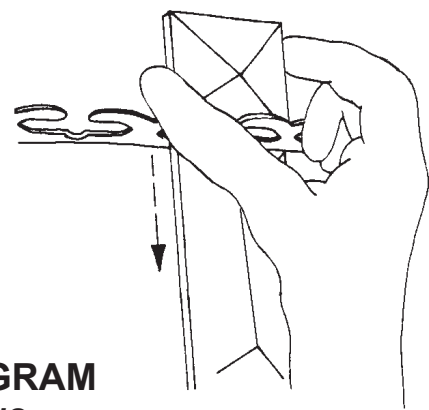

**DIAGRAM #1**

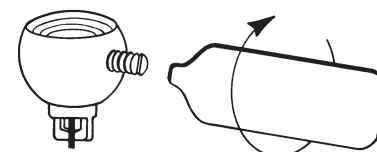

Tighten With  
Tool Provided.



# PLAZA 6673R TRIM DIAGRAM

## Instructions for electrician STEP 2

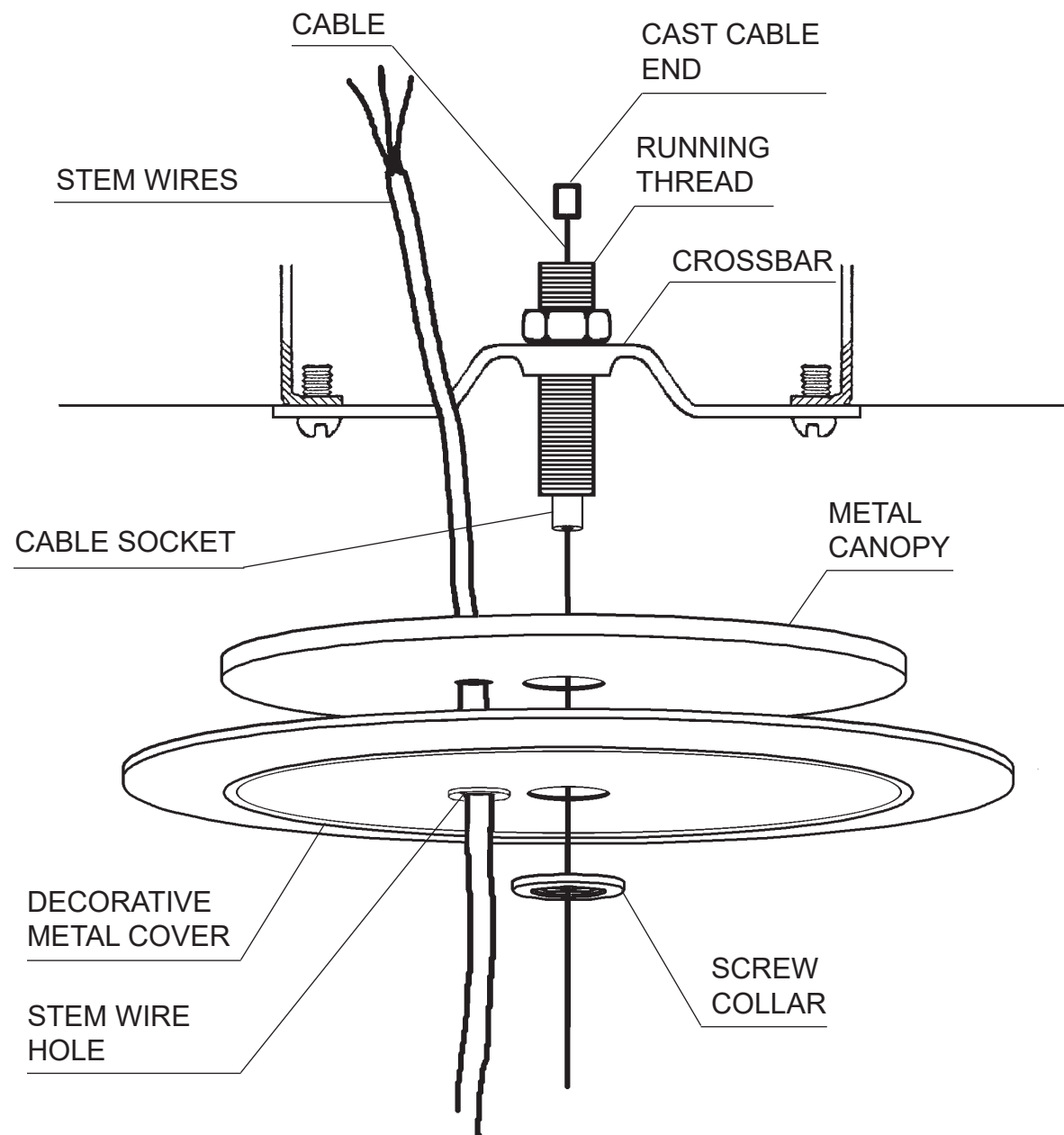

**2** Remove the screw collar, decorative metal cover, metal canopy from the canopy assembly and attach crossbar using hardware (not provided) to outlet box. Feed suspension cable through running thread from the top so that the cast cable end is seated in the inside of the cable socket. Attach crossbar to the ceiling with cable hanging down. Feed suspension cable through the center hole (larger hole) of the metal canopy, decorative metal cover and then screw collar. The metal canopy must be on top of the decorative metal cover. Feed cable into cable glider on chandelier frame and hang to desired height. Loosen the safety nut on the cable glider by turning counter clockwise. Slide cable into glider and allow it to play out of the side of the cable glider temporarily. To adjust height loosen the safety nut and depress it until the cable is released to move the frame up and down the cable. Feed stem wire through the screw collar, stem wire hole, decorative metal cover and metal canopy (the smaller hole). When chandelier is at desired height, trim stem wire and connect ground wire (marked with green tracer) and power wires (black or white tracers) in outlet box. Raise metal canopy and decorative metal cover to ceiling and secure to running thread with the screw collar. Supplied are 4 cable grips. Adjust along stem wire and clip to support cable as desired. Cut suspension cable with cable cutters leaving about 1/2" protruding from the side of the cable glider.



22 Lights  
Diameter: 21"  
Height: 19"  
Hanging Weight: 24 lbs.

THIS DESIGN IS THE PROPRIETARY TRADE DRESS/TRADemark OF W SCHONBEK LLC.



# SCHONBEK

1870

**See diagram on back page  
Follow steps in exact order  
Save this trim diagram for future reference**

**1**

### IMPORTANT

**Person who opens carton should record the following information for future service.**

CODE # \_\_\_\_\_ Four-digit number on outside of carton.  
PACKER # \_\_\_\_\_ See crystal package label.  
ORDER # \_\_\_\_\_ See crystal package label.



# Instructions for crystal trimming

## STEPS 3 - 8

**3** 

You will need 21 - B8  
40 Watts Max  
25 Watts recommended  
(Supplied - Schonbek #: 30025)

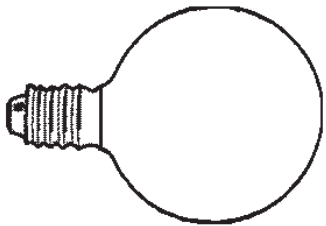

You will need 1 - G16-1/2  
40 Watts Max  
25 Watts recommended  
(Supplied - Schonbek #: 30764)

**Install bulbs and be sure to test fixture BEFORE trimming.**

**4** Install three bottom crystal grids with eleven thumb nuts (already screwed onto grids) to bottom of Rings #1, #3 and #5.

**5** Screw ball "D" onto bottom of grid 87/315/1SR. Tighten set screw to lock into position (Diagram #1).

**6** Hang chain "A" first into Ring #8. Hold chain by the top square crystal. (NOTE: Flat side of large crystals face out!) Insert square crystal into the pocket of the ring. (Diagram #2) Lower the chain until the top square stone seats itself into the ring pocket. When top ring is completely trimmed, hang chain "A" into ring #7.

**7** Starting with ring #2, hang chain "B" by placing the connector in the hole on the ring. (NOTE: FLAT SIDE OF LARGE CRYSTALS FACE OUT!!) When the bottom ring is completely trimmed hang chain "B" into ring #4.

**8** Hang chain "C" into ring #6. Hold chain by the top square crystal. (NOTE: FLAT SIDE OF LARGE CRYSTALS FACE OUT AND CHAINS ARE SYMMETRICAL SO EITHER END WILL WORK.) Insert square crystal into the pocket of the ring. (Diagram #2) Lower the chain until the top square stone seats itself into the ring pocket.

**DIAGRAM #2**

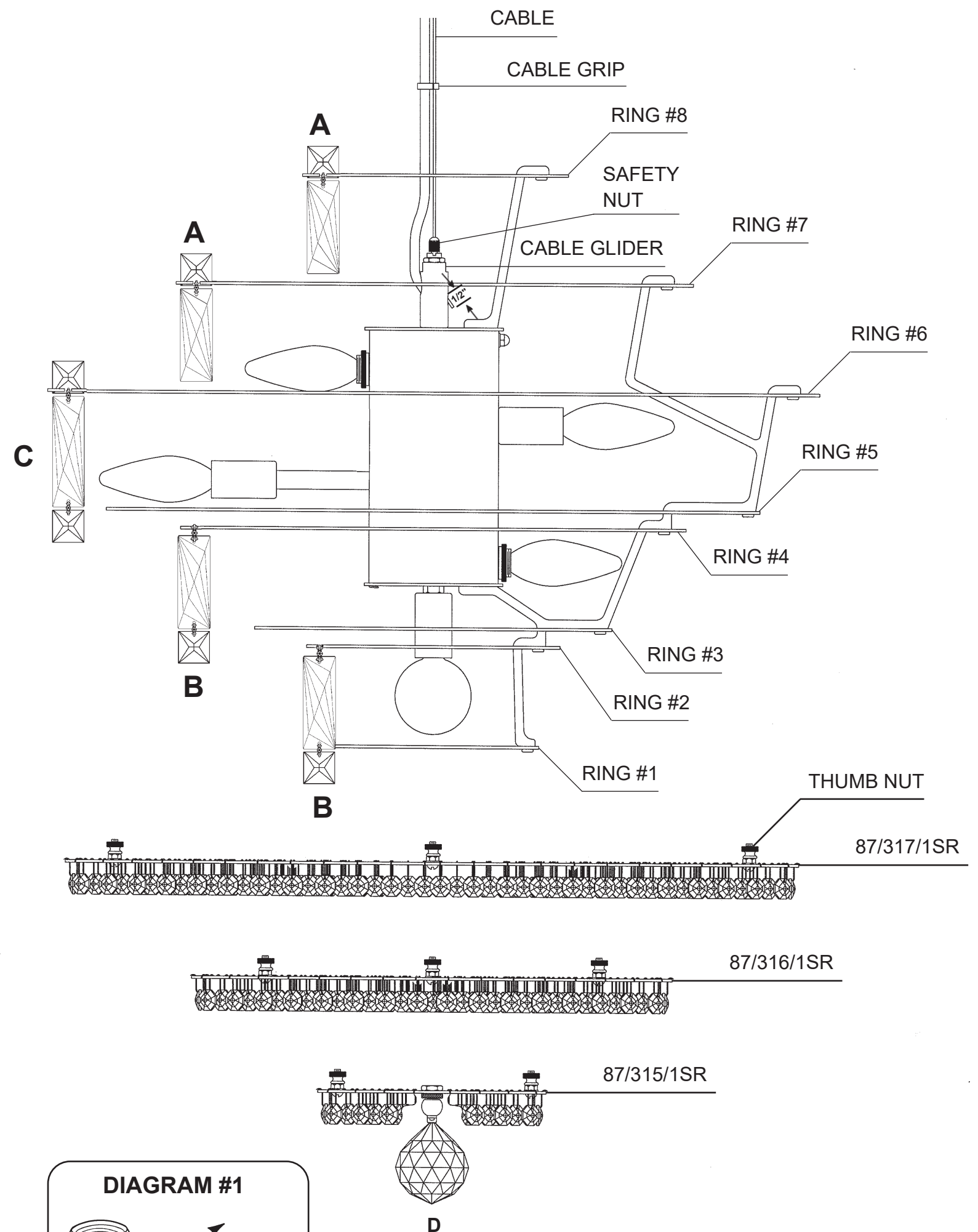
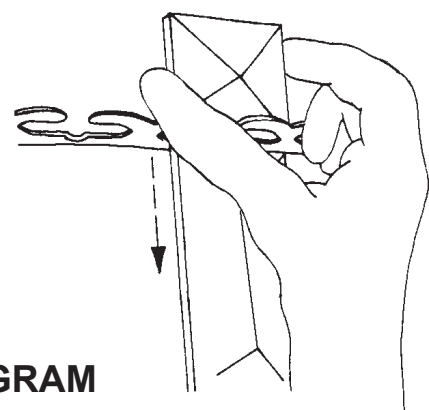

**DIAGRAM #1**

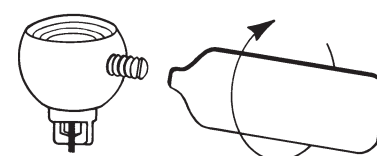

**Tighten With Tool Provided.**



**Instructions for electrician  
STEP 2**

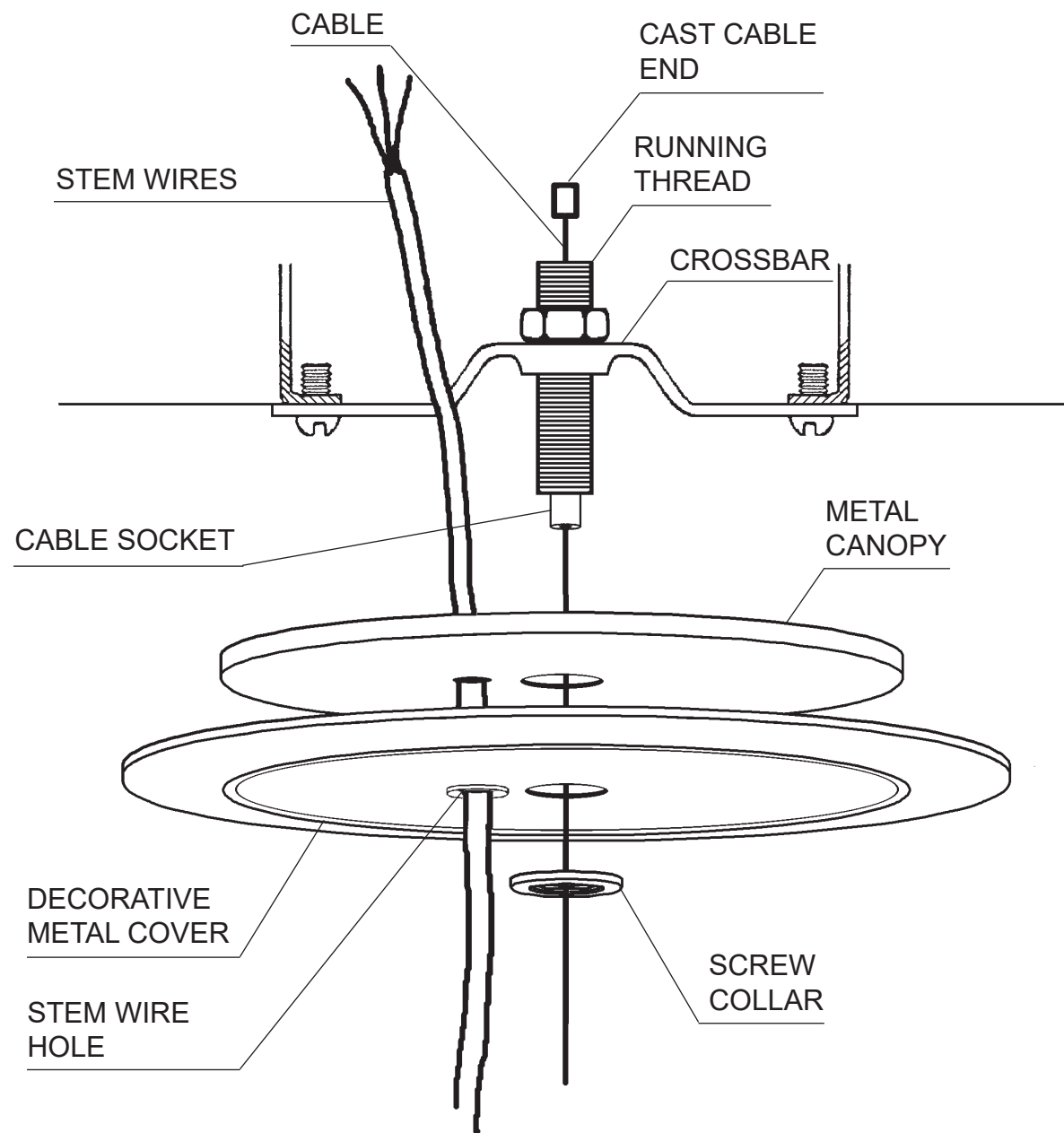

**2** Remove the screw collar, decorative metal cover, metal canopy from the canopy assembly and attach crossbar using hardware (not provided) to outlet box. Feed suspension cable through running thread from the top so that the cast cable end is seated in the inside of the cable socket. Attach crossbar to the ceiling with cable hanging down. Feed suspension cable through the center hole (larger hole) of the metal canopy, decorative metal cover and then screw collar. The metal canopy must be on top of the decorative metal cover. Feed cable into cable glider on chandelier frame and hang to desired height. Loosen the safety nut on the cable glider by turning counter clockwise. Slide cable into glider and allow it to play out of the side of the cable glider temporarily. To adjust height loosen the safety nut and depress it until the cable is released to move the frame up and down the cable. Feed stem wire through the screw collar, stem wire hole, decorative metal cover and metal canopy (the smaller hole). When chandelier is at desired height, trim stem wire and connect ground wire (marked with green tracer) and power wires (black or white tracers) in outlet box. Raise metal canopy and decorative metal cover to ceiling and secure to running thread with the screw collar. Supplied are 4 cable grips. Adjust along stem wire and clip to support cable as desired. Cut suspension cable with cable cutters leaving about 1/2" protruding from the side of the cable glider.

**PLAZA 6673-\_\_\_ TRIM DIAGRAM**

(Trim Option)



THIS DESIGN IS THE PROPRIETARY TRADE DRESS/TRADemark OF W SCHONBEK LLC.

22 Lights  
Diameter: 21"  
Height: 19"  
Hanging Weight: 24 lbs.



**SCHONBEK** | 1870

**See diagram on back page  
Follow steps in exact order  
Save this trim diagram for future reference**

**1**

**IMPORTANT**

*Person who opens carton should record the following information for future service.*

CODE # \_\_\_\_\_ Four-digit number on outside of carton.  
PACKER # \_\_\_\_\_ See crystal package label.  
ORDER # \_\_\_\_\_ See crystal package label.



# Instructions for crystal trimming

## STEPS 3 - 8

**3** 

You will need 21 - B8  
40 Watts Max  
25 Watts recommended  
(Supplied - Schonbek #: 30025)

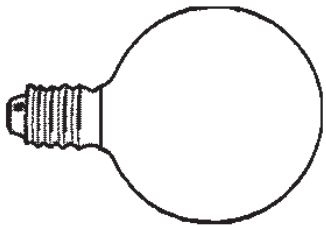

You will need 1 - G16-1/2  
40 Watts Max  
25 Watts recommended  
(Supplied - Schonbek #: 30764)

**Install bulbs and be sure to test fixture BEFORE trimming.**

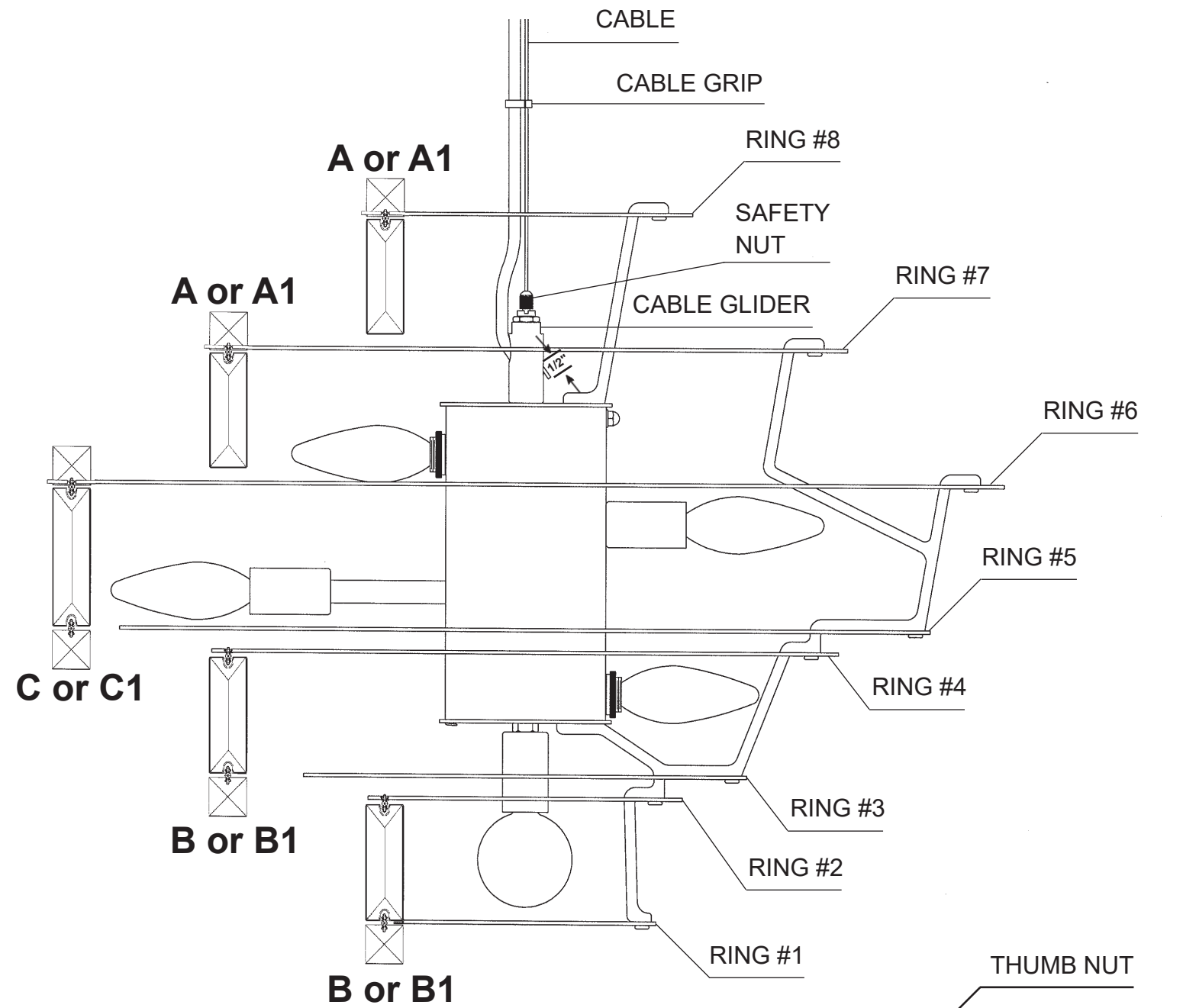

**4** Install three bottom crystal grids with eleven thumb nuts (already screwed onto grids) to bottom of Rings #1, #3 and #5.

**5** Screw ball "D" onto bottom of grid 87/315/1SS. Tighten set screw to lock into position (Diagram #1).

**6** Hang chain "A" first into Ring #8. Hold chain by the top square crystal. (NOTE: Flat side of large crystals face out!) When trimming a ST fixture, alternate hanging A & A1 chains. Insert square crystal into the pocket of the ring. (Diagram #2) Lower the chain until the top square stone seats itself into the ring pocket. When top ring is completely trimmed, hang chain "A" into ring #7.

**7** Starting with ring #2, hang chain "B" by placing the connector in the hole on the ring. (NOTE: FLAT SIDE OF LARGE CRYSTALS FACE OUT!!) When trimming a ST fixture, alternate hanging B & B1 chains. When the bottom ring is completely trimmed hang chain "B" into ring #4.

**8** Hang chain "C" into ring #6. Hold chain by the top square crystal. (NOTE: FLAT SIDE OF LARGE CRYSTALS FACE OUT AND CHAINS ARE SYMMETRICAL SO EITHER END WILL WORK.) When trimming a ST fixture, alternate hanging C & C1 chains. Insert square crystal into the pocket of the ring. (Diagram #2) Lower the chain until the top square stone seats itself into the ring pocket.

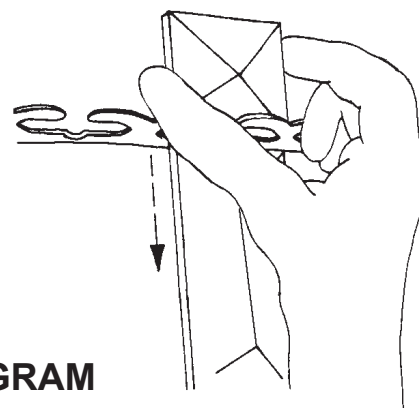

**DIAGRAM #2**

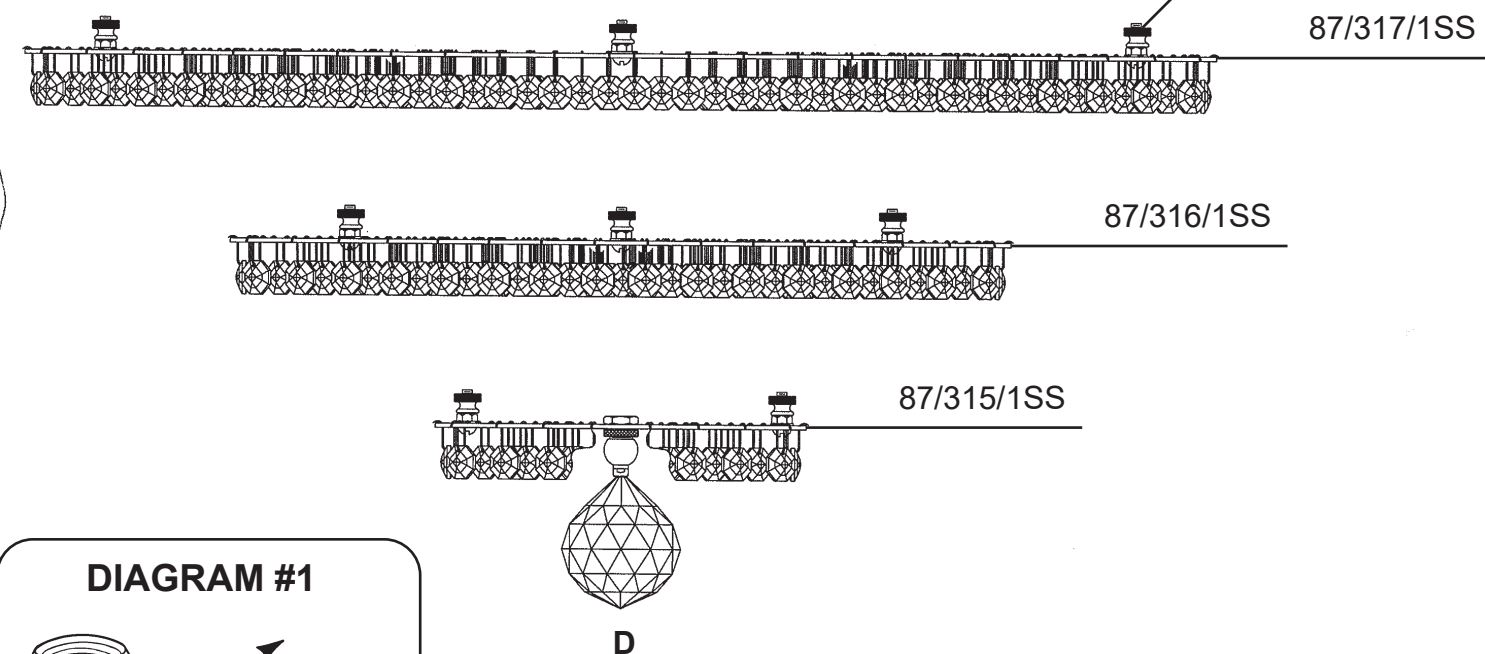

**DIAGRAM #1**

**Tighten With Tool Provided.**

