

Instructions for electrician
STEPS 2 - 10

WARNING:

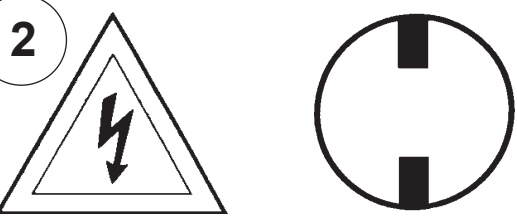

Electrical Danger

Turn Power Off

All electrical components must be installed by a licensed electrician in accordance with the National Electric Code and the appropriate local electrical codes.

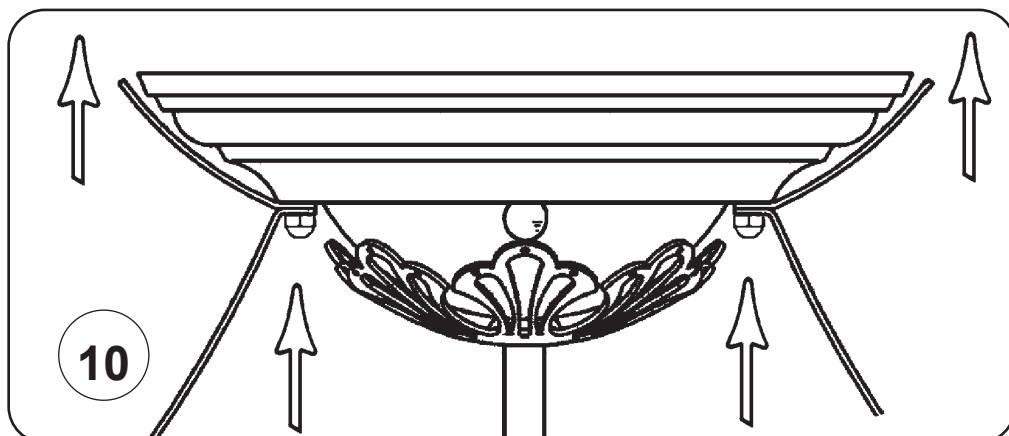
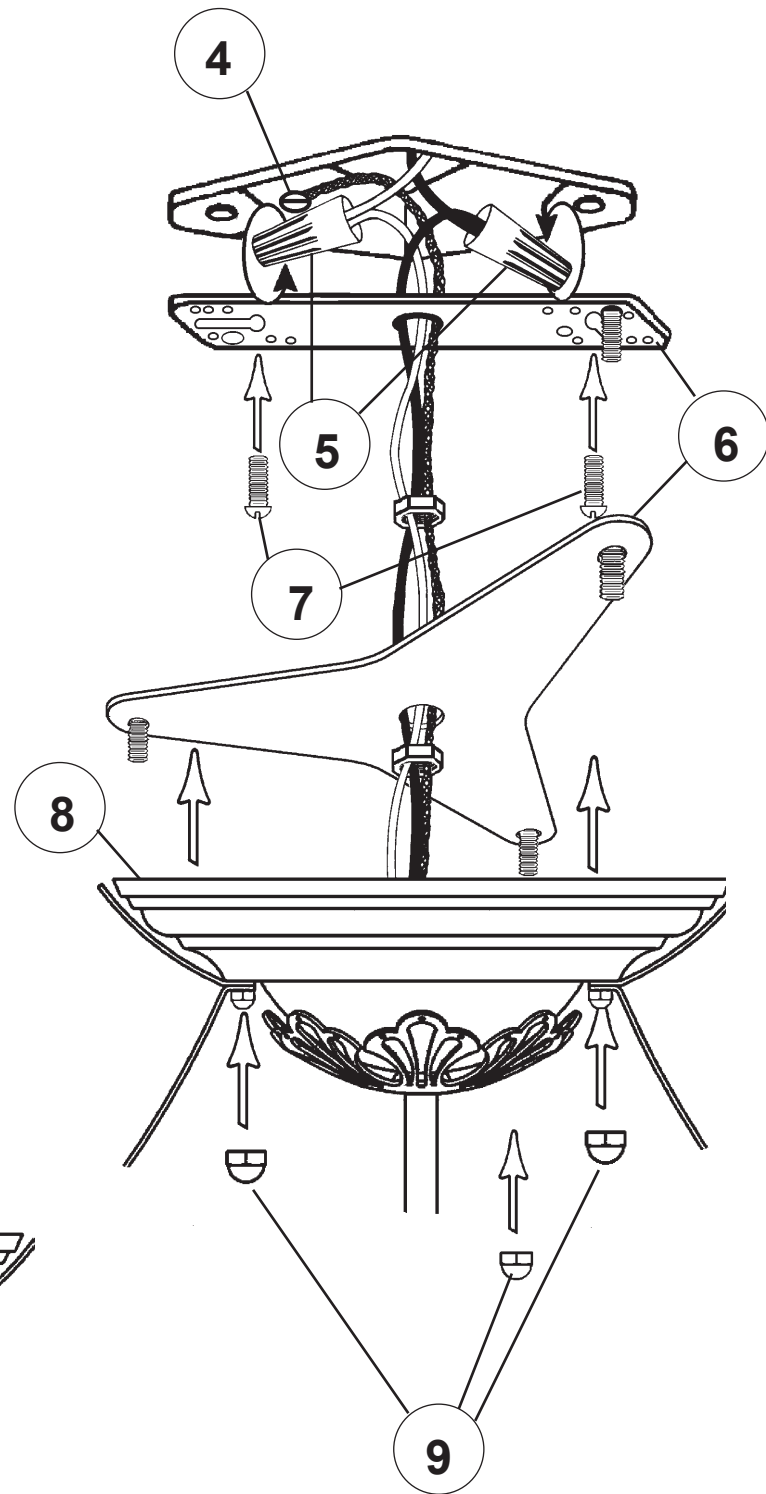
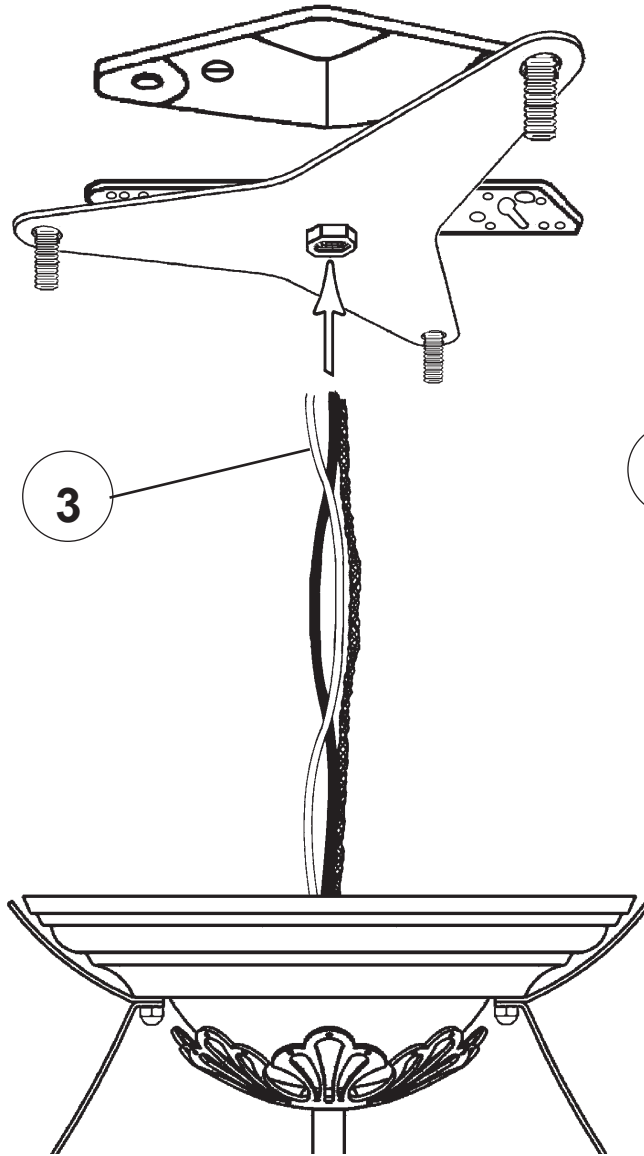

CHANDELIER 9845-___ __R TRIM DIAGRAM

(Finish Option)



17 Lights
Diameter: 30"
Body Length: 19-1/2"
Hanging Weight: 22 lbs.

THIS DESIGN IS THE PROPRIETARY TRADE DRESS/TRADemark OF W SCHONBEK LLC.



SCHONBEK | 1870

See diagram on back page
Follow steps in exact order
Save this trim diagram for future reference

IMPORTANT

1

Person who opens carton should record the following information for future service.

CODE # _____ Four-digit number on outside of carton.
PACKER # _____ See crystal package label.
ORDER # _____ See crystal package label.



Instructions for crystal trimming

STEPS 11 - 12



11
 You will need 17 - B10
 25 Watts Recommended
 60 Watts Max

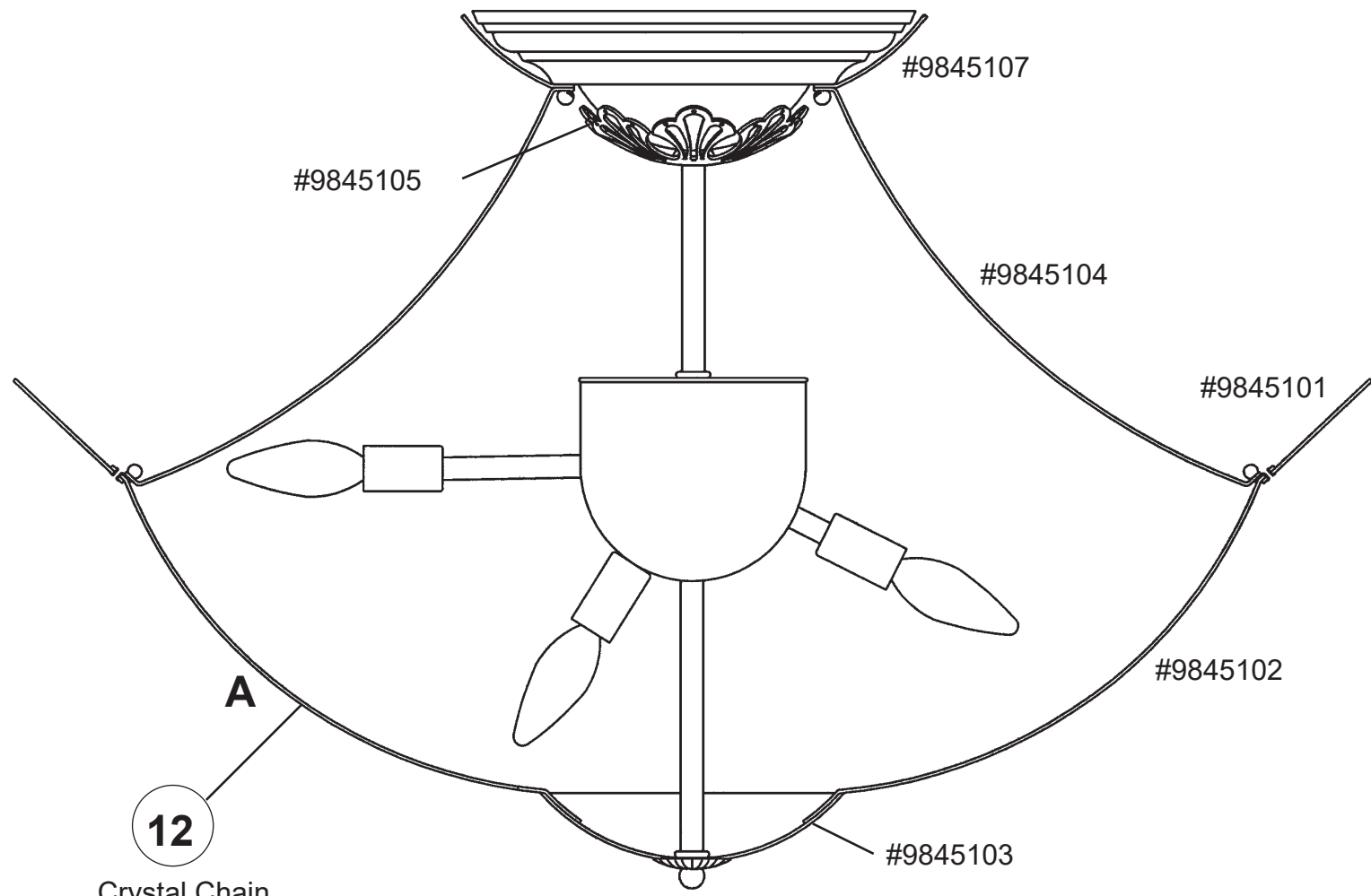

12
 Crystal Chain
 has a small
 jewel at bottom.

PART NUMBERS FOR SPARE PARTS

