

 **SCHONBEK** | 1870

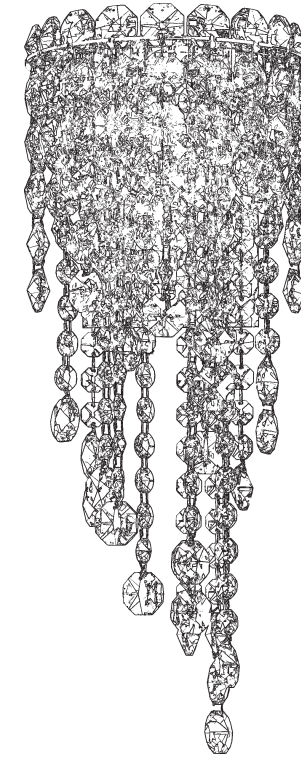







CHANTANT
CH0832N- __ __ O



THIS DESIGN IS THE PROPRIETARY
TRADE DRESS/TRADEMARK OF
W SCHONBEK LLC.

2 Lights
Length: 6-1/2"
Height: 16"
Extension: 6"
Hanging Weight: 5lbs.

 **SCHONBEK** | 1870

			S					
MAX 40 W	110-120 V							

2 X  : G9 40W MAX 

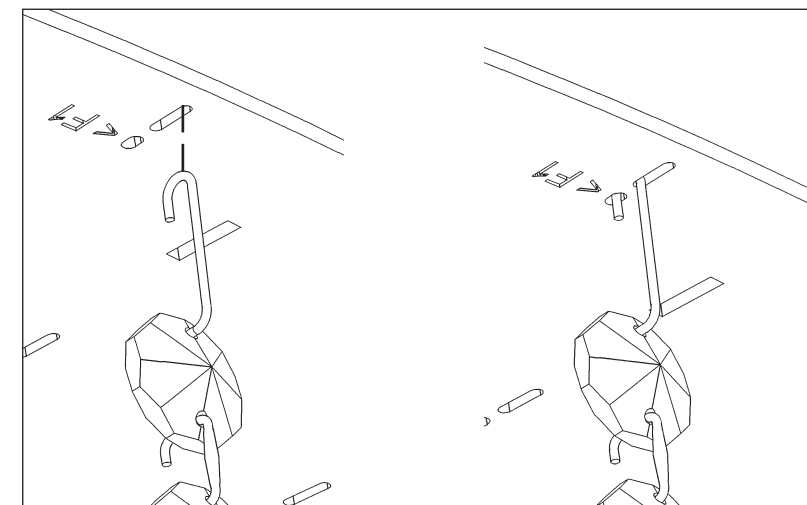
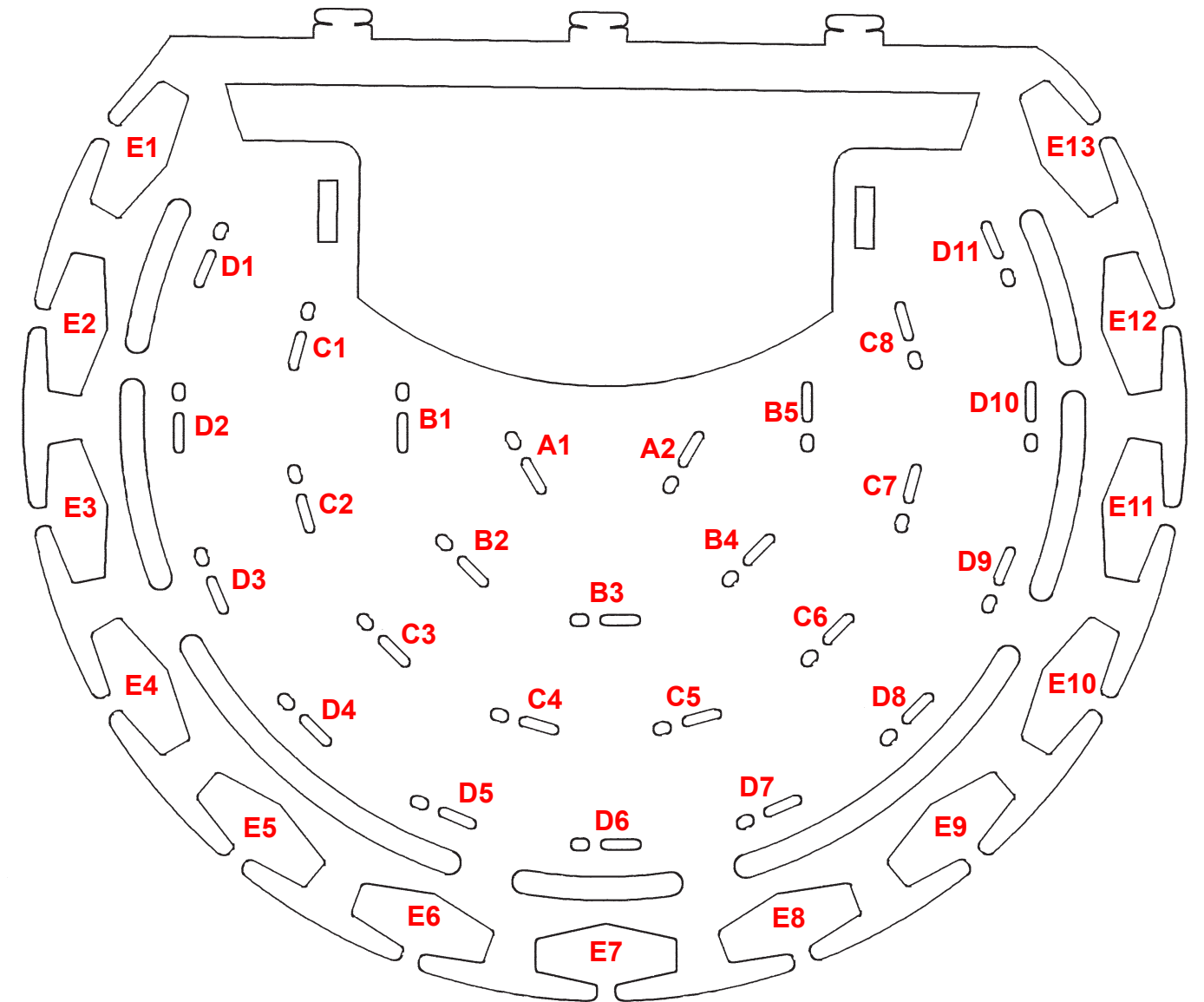
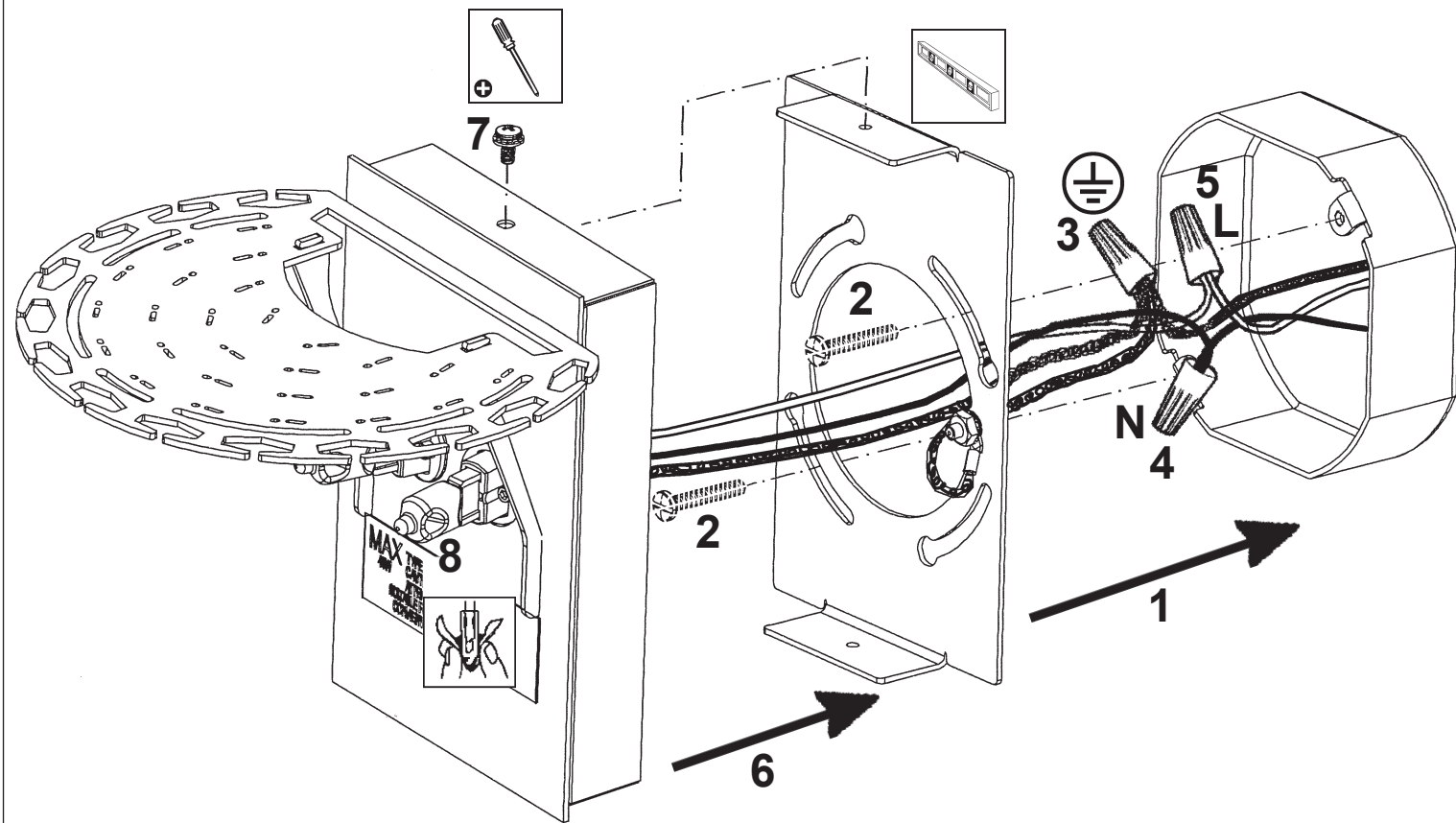

- 9 A1 - A2
- 10 B1 - B5
- 11 C1 - C8
- 12 D1 - D11
- 13 E1 - E13

After hanging all trim, remove labels from crystals. If residue remains, wipe off crystal with a soft, dry cloth.

 **SCHONBEK** | 1870



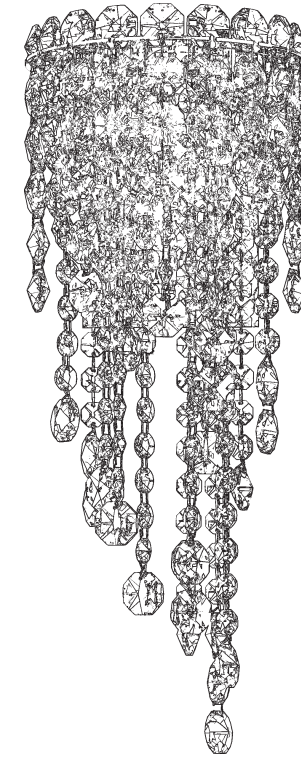





CHANTANT
CH0832N- __ __ R



THIS DESIGN IS THE PROPRIETARY
TRADE DRESS/TRADEMARK OF
W SCHONBEK LLC.

2 Lights
Length: 6-1/2"
Height: 16"
Extension: 6"
Hanging Weight: 5lbs.

 **SCHONBEK** | 1870

			S					
MAX 40 W	110-120 V							

2 X  : G9 40W MAX 

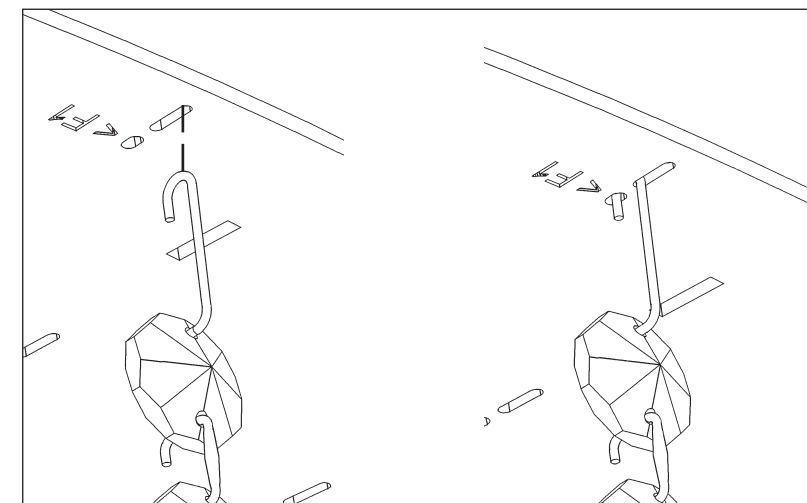
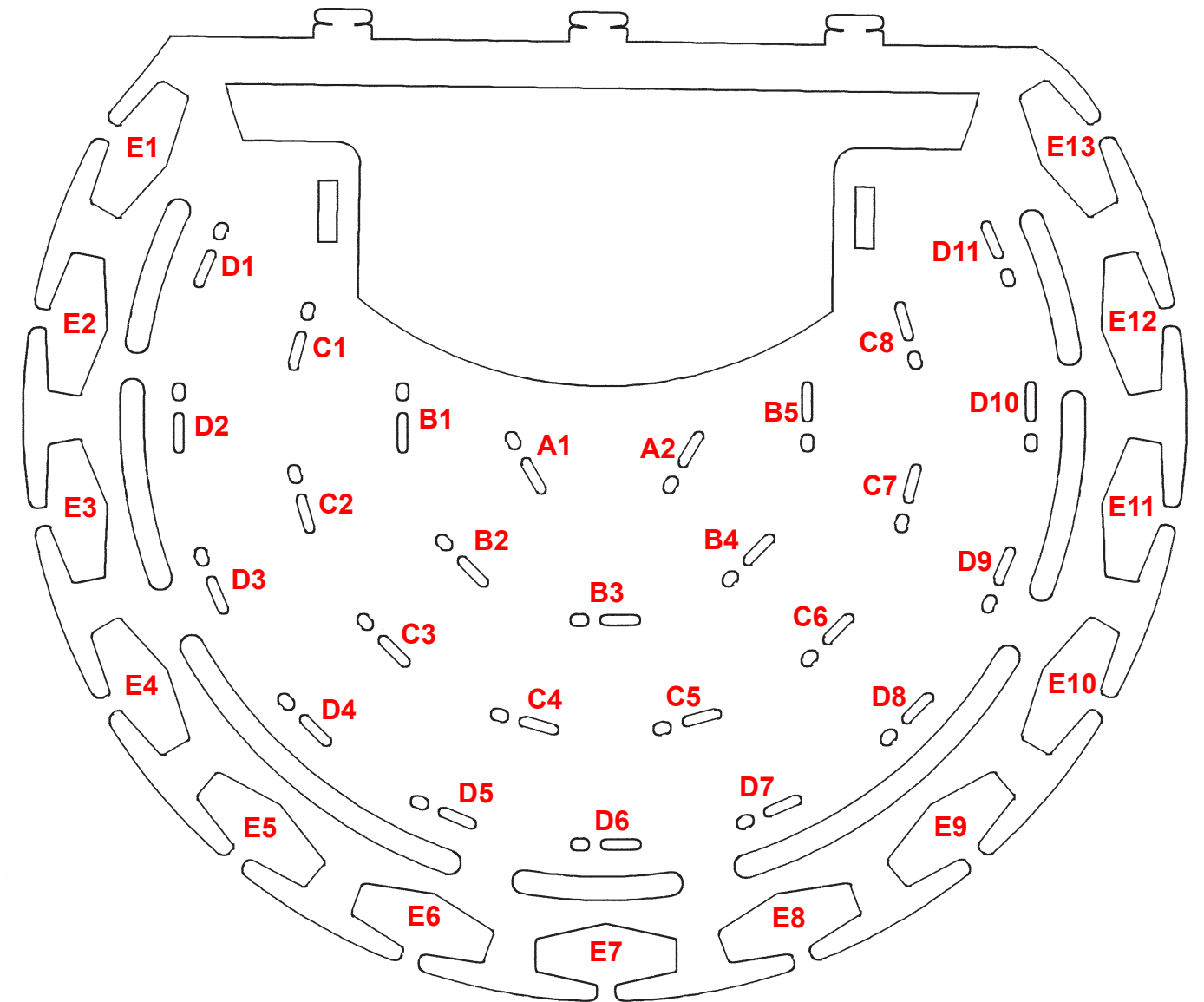
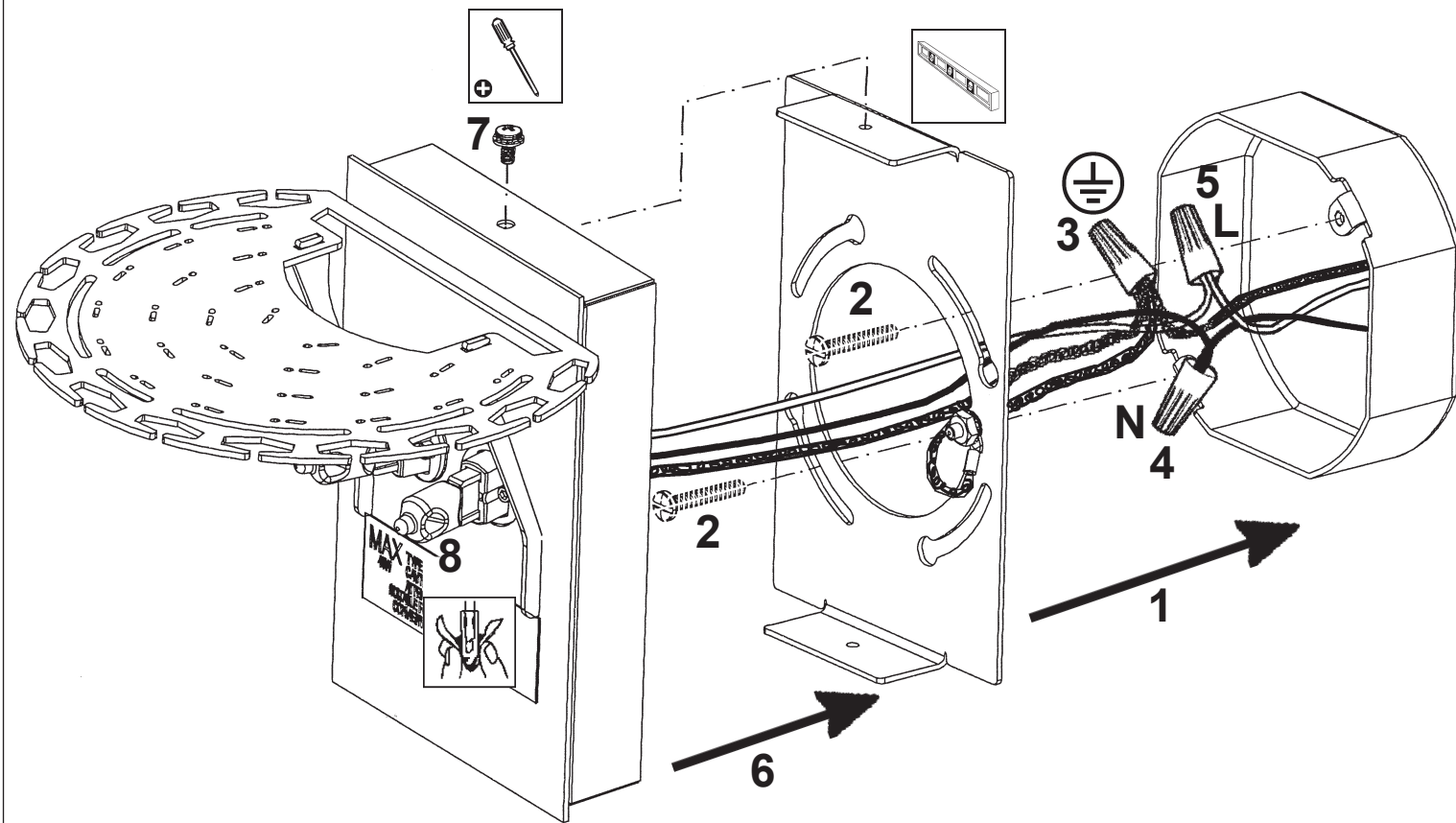

- 9 A1 - A2
- 10 B1 - B5
- 11 C1 - C8
- 12 D1 - D11
- 13 E1 - E13

After hanging all trim, remove labels from crystals. If residue remains, wipe off crystal with a soft, dry cloth.