

HAMILTON NOUVEAU HA5802N-\_\_ \_\_H



2 Light  
 Diameter: 14-1/2"  
 Height: 16"  
 Extension: 6-1/2"  
 Hanging Weight: 5 lbs.

**T**HIS DESIGN IS THE PROPRIETARY  
 TRADE DRESS/TRADemark OF  
 W SCHONBEK LLC.

SCHONBEK  
*Circa*  
 1870-1930

SCHONBEK  
*Circa*  
 1870-1930

MAX 60 W	110-120 V							

**WARNING:**

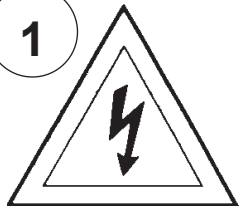
1  **Electrical Danger**

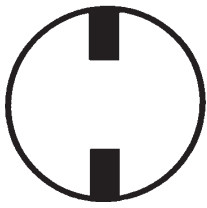
 **Turn Power Off**

All electrical components must be installed by a licensed electrician in accordance with the National Electric Code and the appropriate local electrical codes.

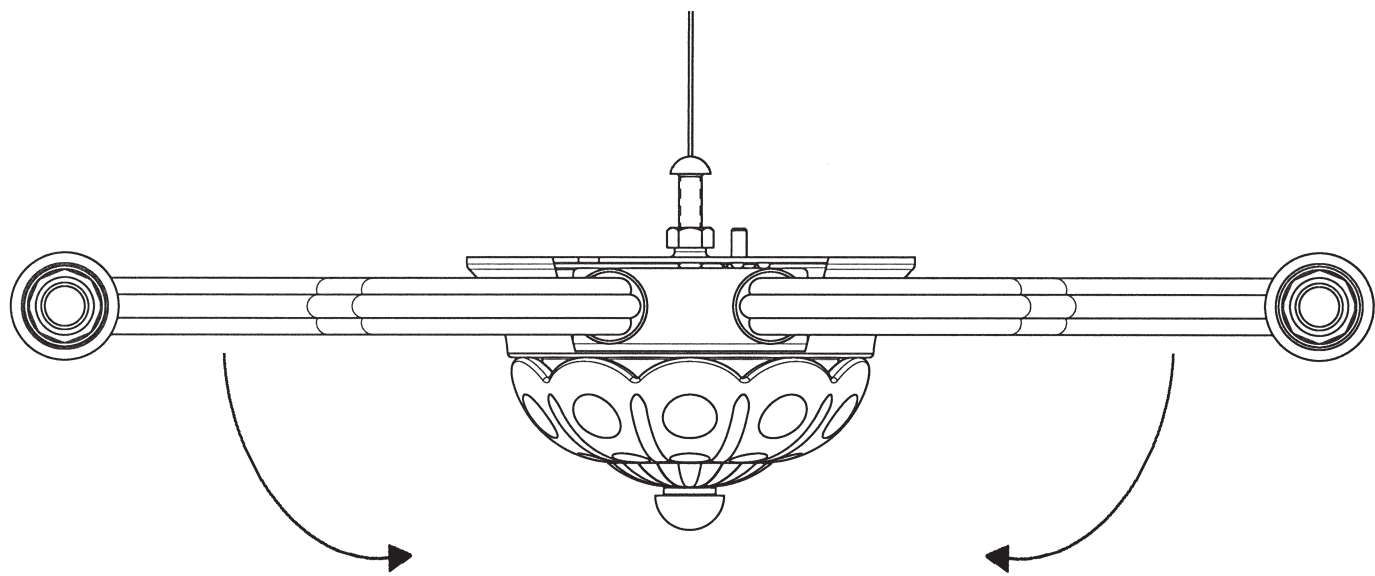
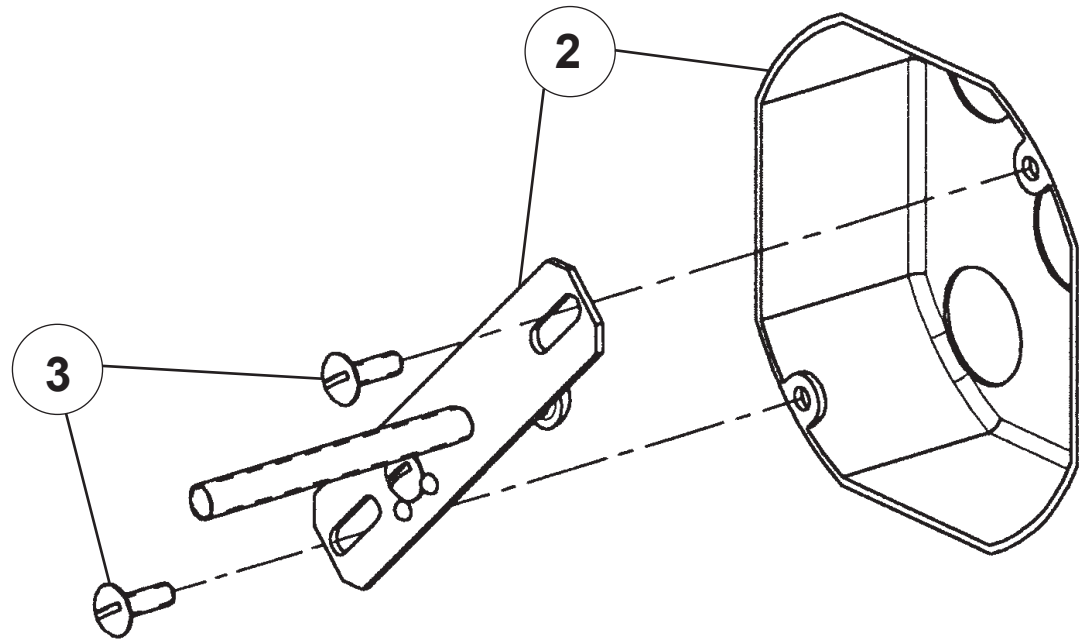

4 Turn arms to line up holes in arms with dimple in plate. Tighten lock washer and nut to secure arms in place.

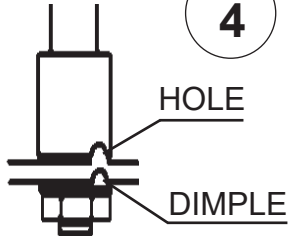

HOLE

DIMPLE

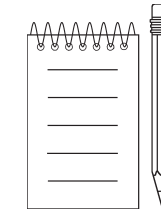

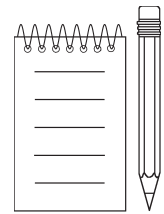

10

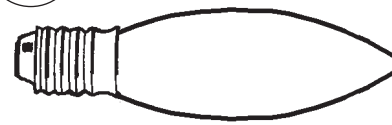

You will need 2 - B10  
25 Watts Recommended  
60 Watts Max

Install bulbs and be sure  
to test fixture **BEFORE**  
trimming.

