

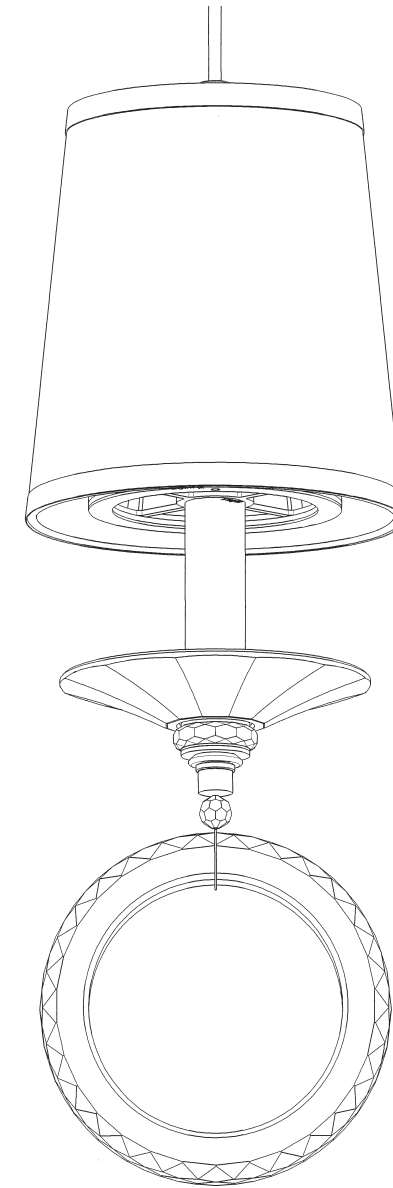

# EMILEA MA1003N-\_\_ \_\_O



**T**HIS DESIGN IS THE PROPRIETARY TRADE DRESS/TRADEMARK OF W SCHONBEK LLC.

1 Light  
Diameter: 5-1/2"  
Height: 16-1/2"  
Hanging Weight: 3lbs.



MAX <u>40</u> W	110-120 V							

**1** **WARNING:**

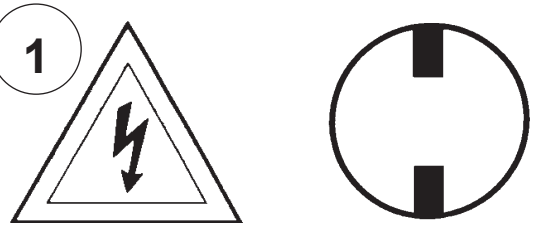

**Electrical Danger Turn Power Off**

All electrical components must be installed by a licensed electrician in accordance with the National Electric Code and the appropriate local electrical codes.



**2**

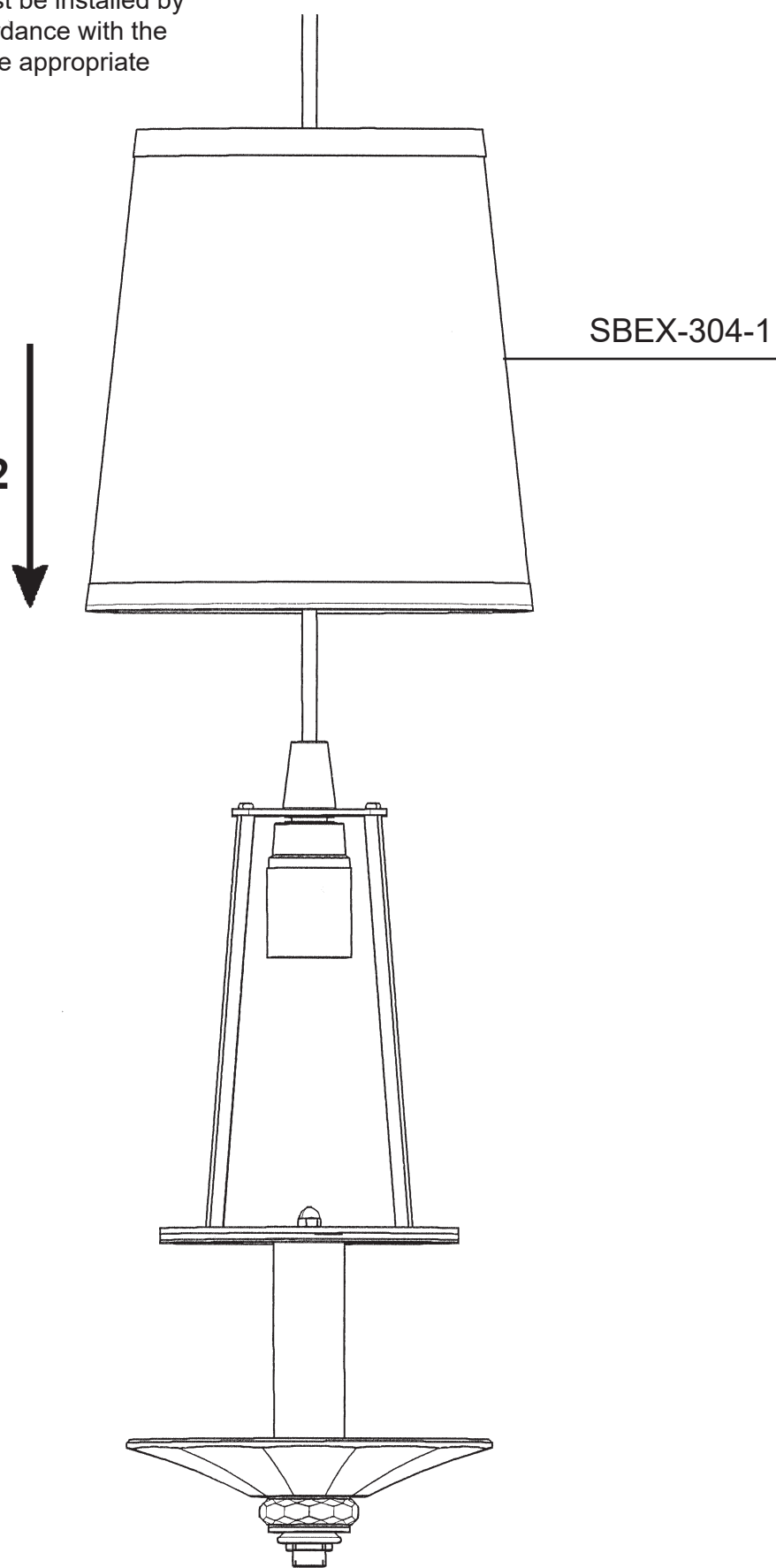

You will need 1 - B10  
25 Watts Recommended  
40 Watts Max

**Install bulbs and be sure  
to test fixture BEFORE  
trimming.**

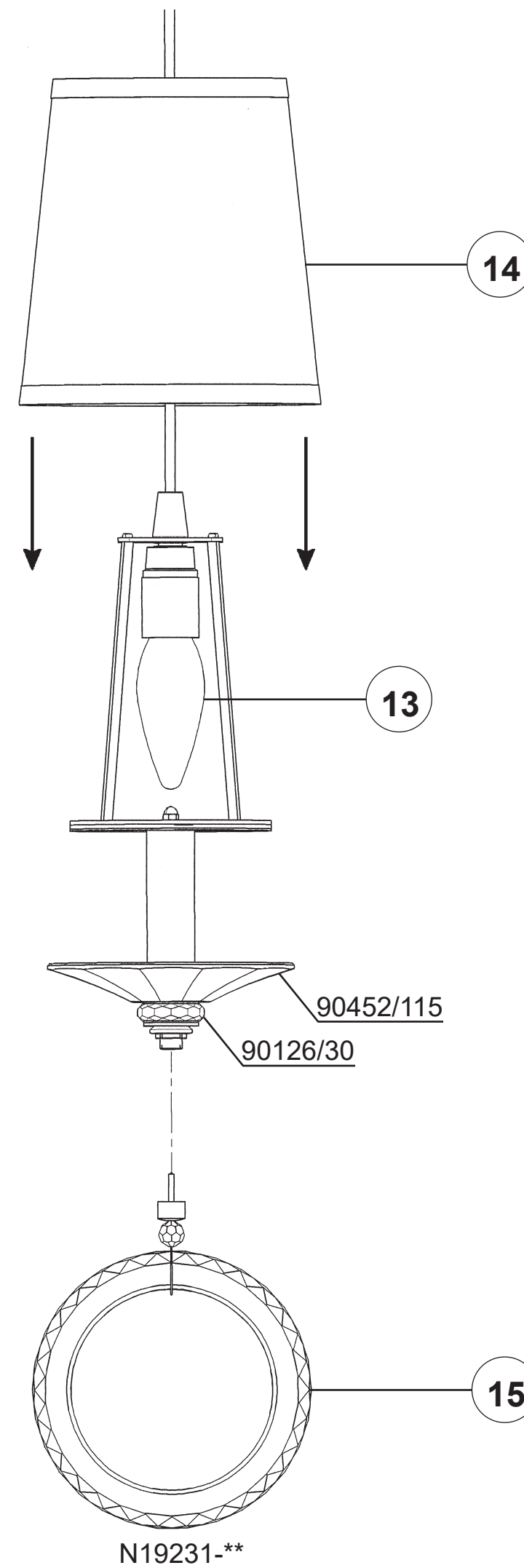

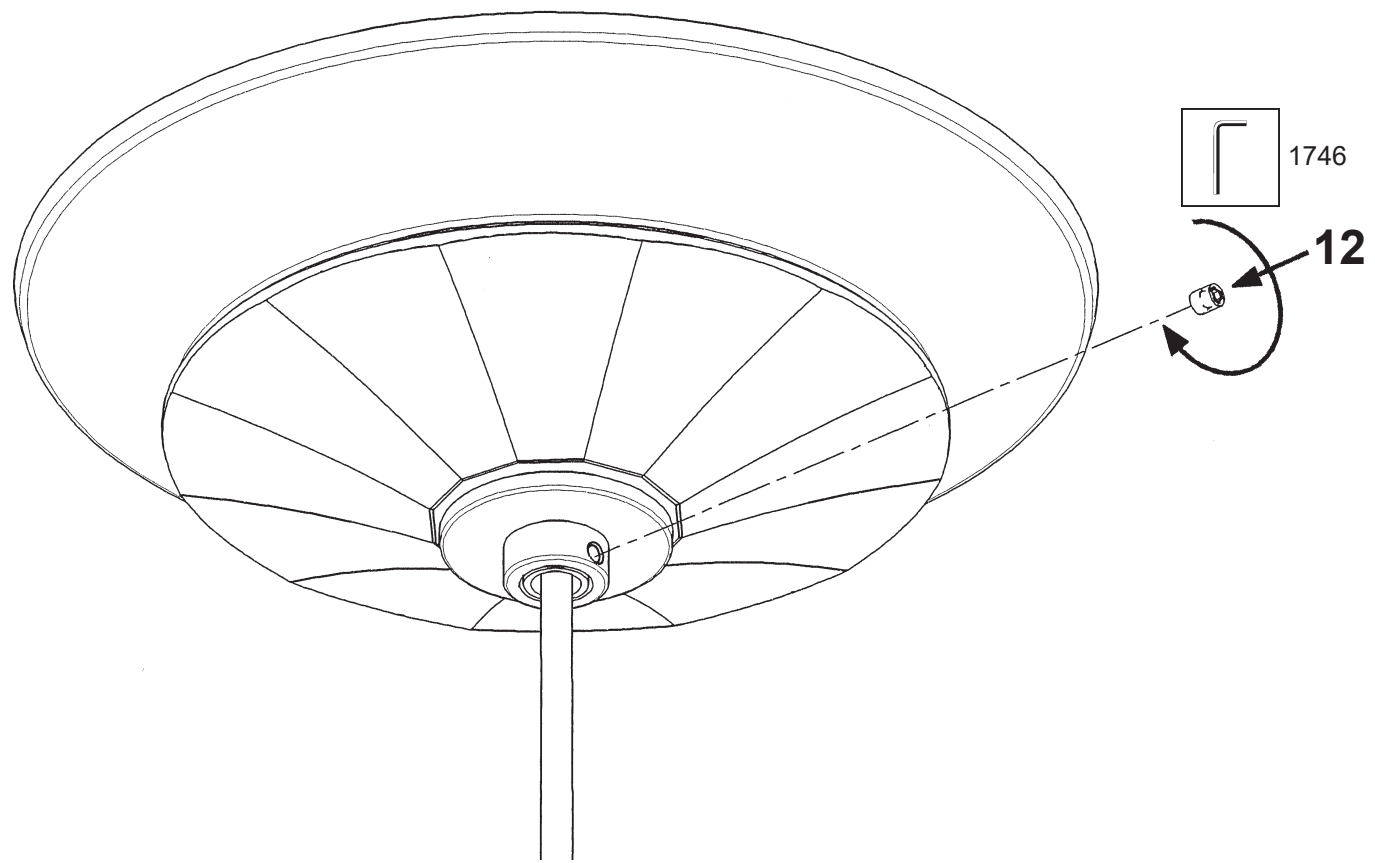

1 X  : 1746

