

# SONATINA ST1946N- \_\_ \_\_ H













10 Lights  
Diameter: 25-1/2"  
Height: 29-1/2"  
Hanging Weight: 25lbs.

**T**HIS DESIGN IS THE PROPRIETARY  
TRADE DRESS/TRADEMARK OF  
W SCHONBEK LLC.

 **SCHONBEK** | 1870

 **SCHONBEK** | 1870

								
MAX 60 W	110-120 V							

**WARNING:**

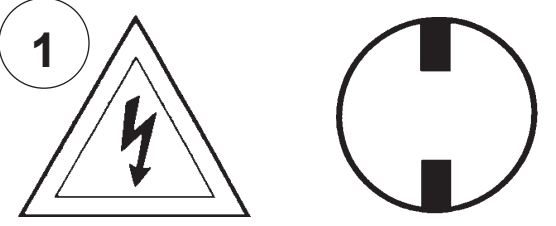
1 

**Electrical Danger Turn Power Off**

All electrical components must be installed by a licensed electrician in accordance with the National Electric Code and the appropriate local electrical codes.

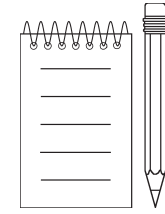
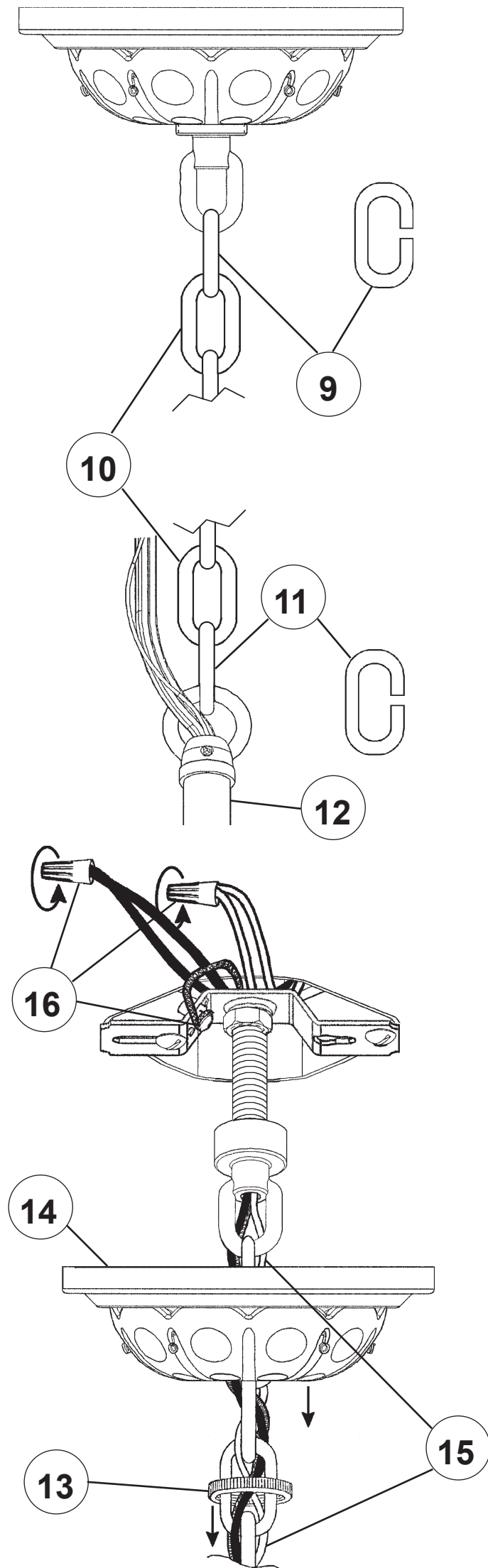
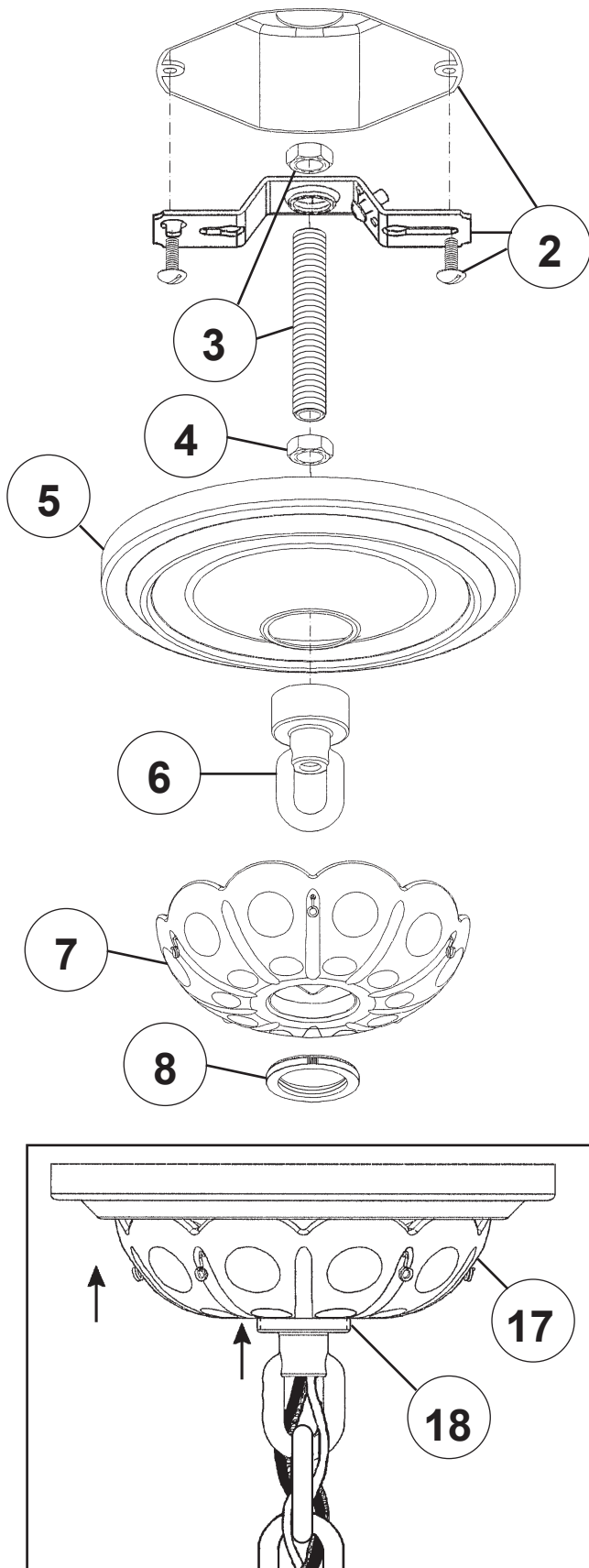

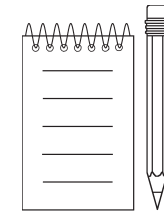
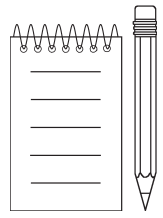

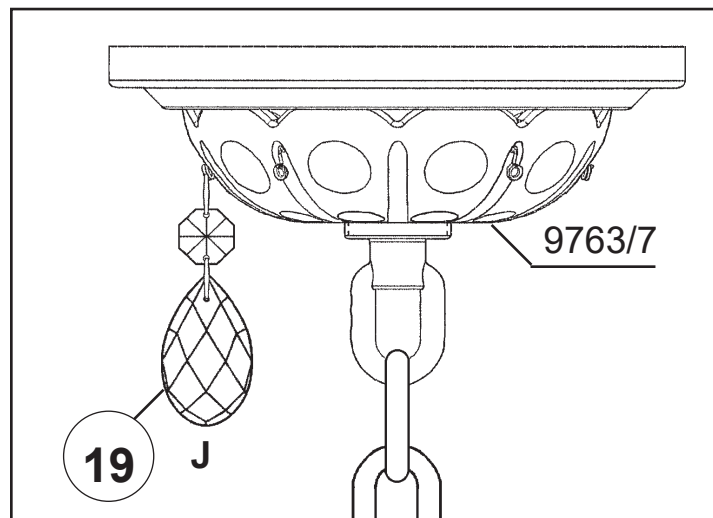

**20**

You will need 10 - B10  
25 Watts Recommended  
60 Watts Max

**Install bulbs and be sure  
to test fixture BEFORE  
trimming.**

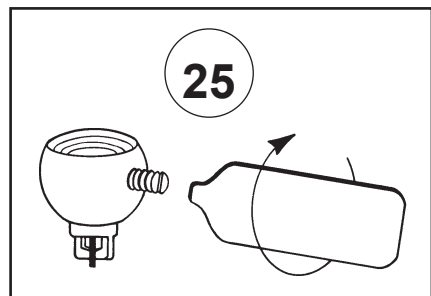
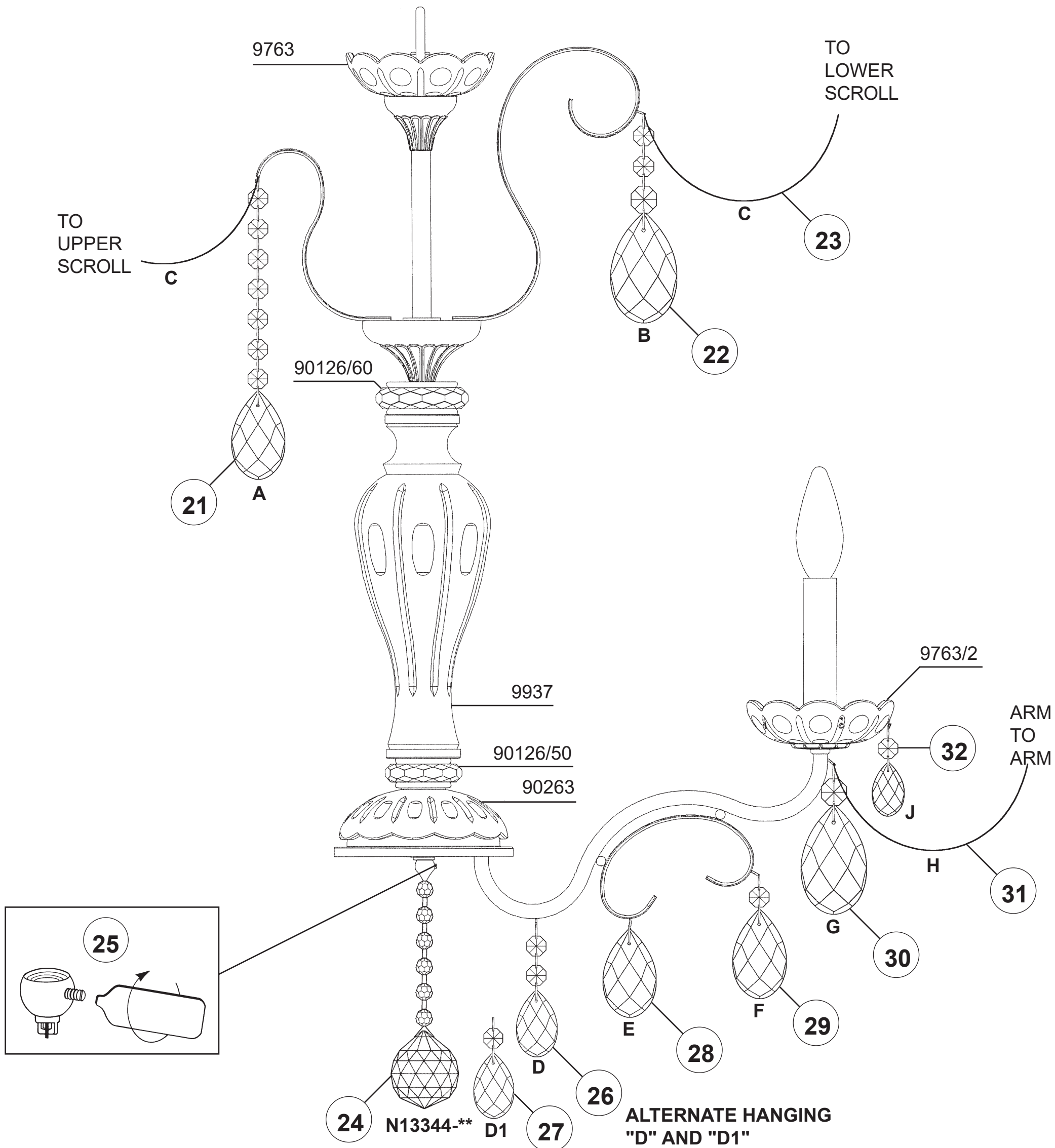

# SONATINA ST1946N- \_\_ \_\_ S













10 Lights  
Diameter: 25-1/2"  
Height: 29-1/2"  
Hanging Weight: 25lbs.

**T**HIS DESIGN IS THE PROPRIETARY  
TRADE DRESS/TRADEMARK OF  
W SCHONBEK LLC.

 **SCHONBEK** | 1870

 **SCHONBEK** | 1870

								
MAX <u>60</u> W	110-120 V							

**WARNING:**

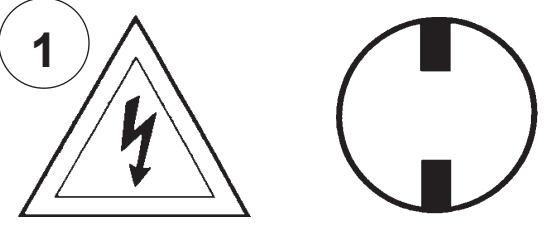
1 

**Electrical Danger Turn Power Off**

All electrical components must be installed by a licensed electrician in accordance with the National Electric Code and the appropriate local electrical codes.

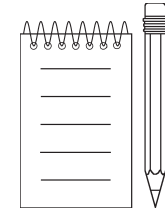
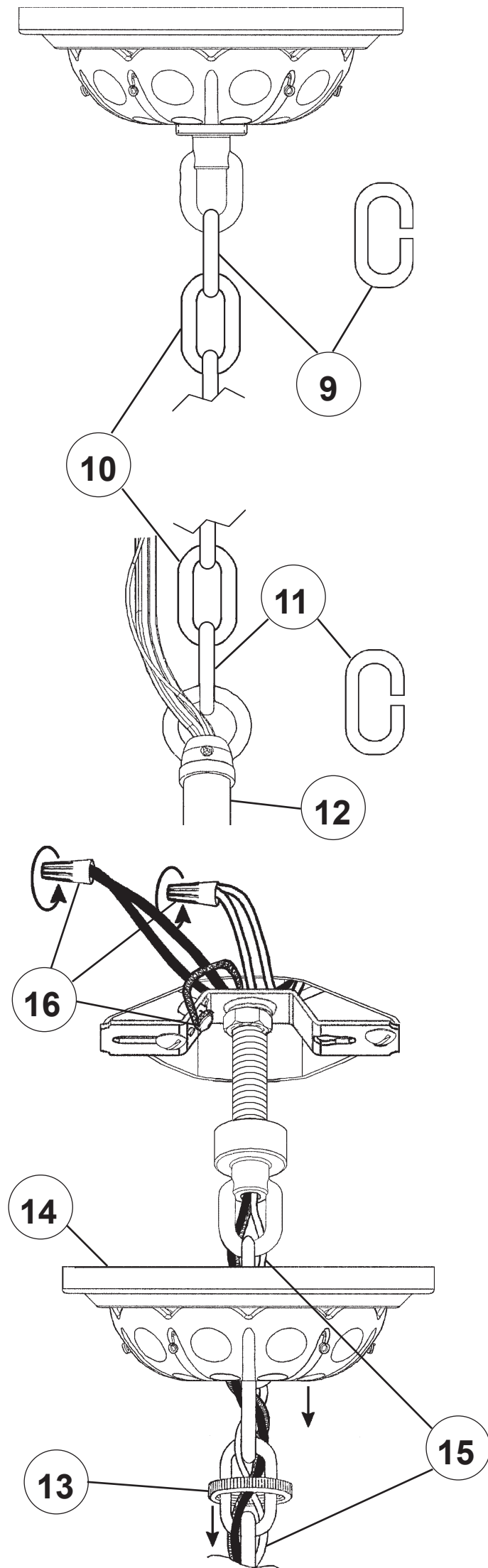
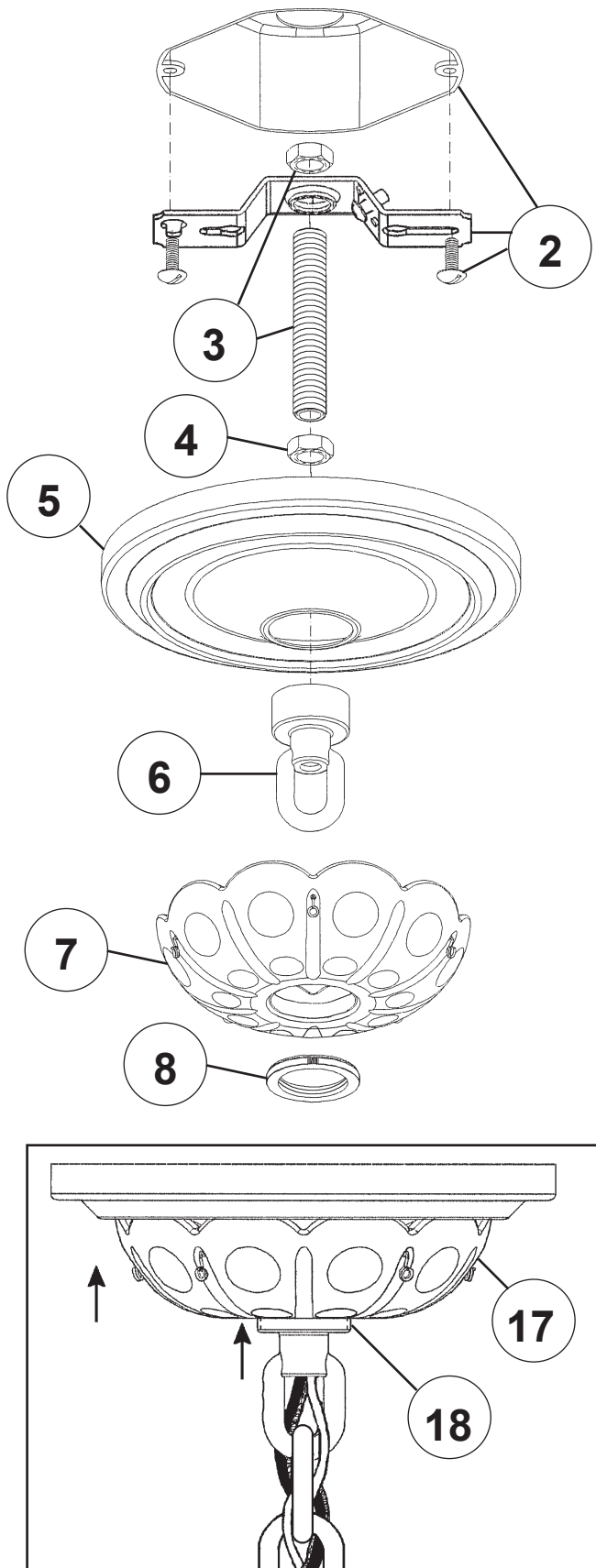

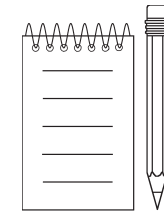
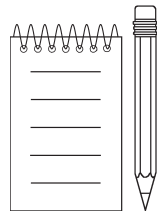

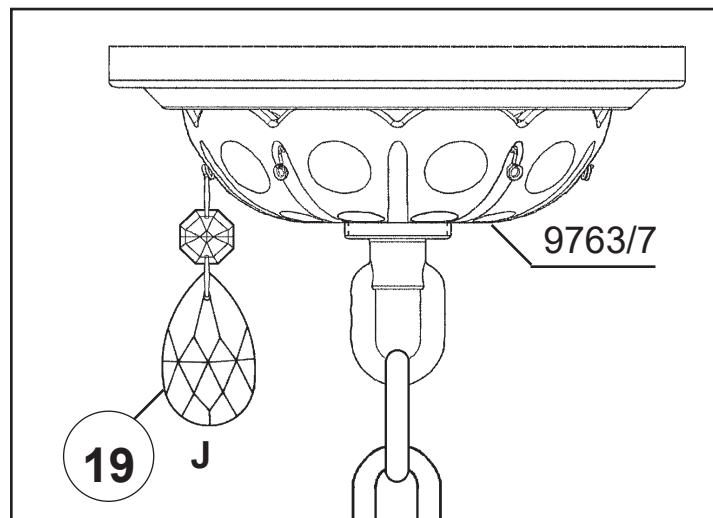

**20**

You will need 10 - B10  
25 Watts Recommended  
60 Watts Max

**Install bulbs and be sure  
to test fixture BEFORE  
trimming.**

