

 **SCHONBEK** | 1870

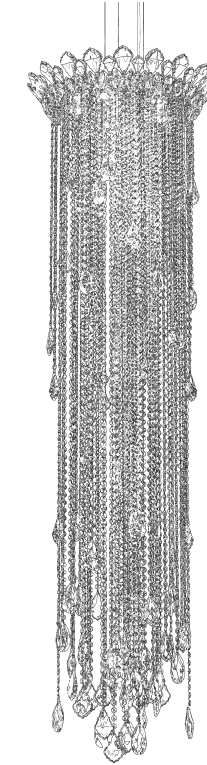







TRILLIANE STRANDS
TR1813N- __ __ H



THIS DESIGN IS THE PROPRIETARY
TRADE DRESS/TRADEMARK OF
W SCHONBEK LLC.

5 Lights
Diameter: 21"
Height: 72"
Hanging Weight: 41lbs.

 **SCHONBEK** | 1870

			S					
MAX 50 W	110-120 V							

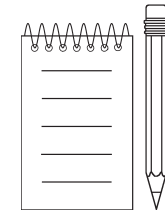
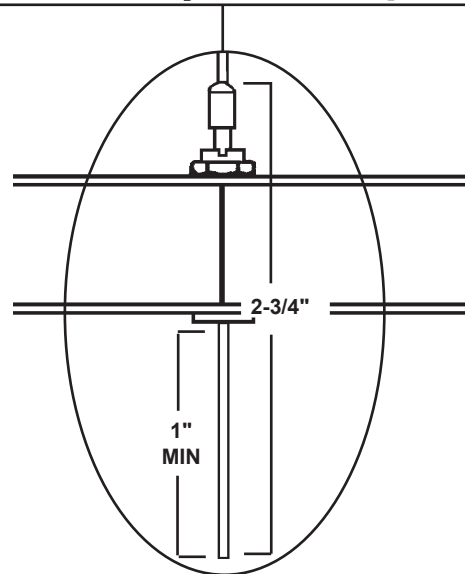
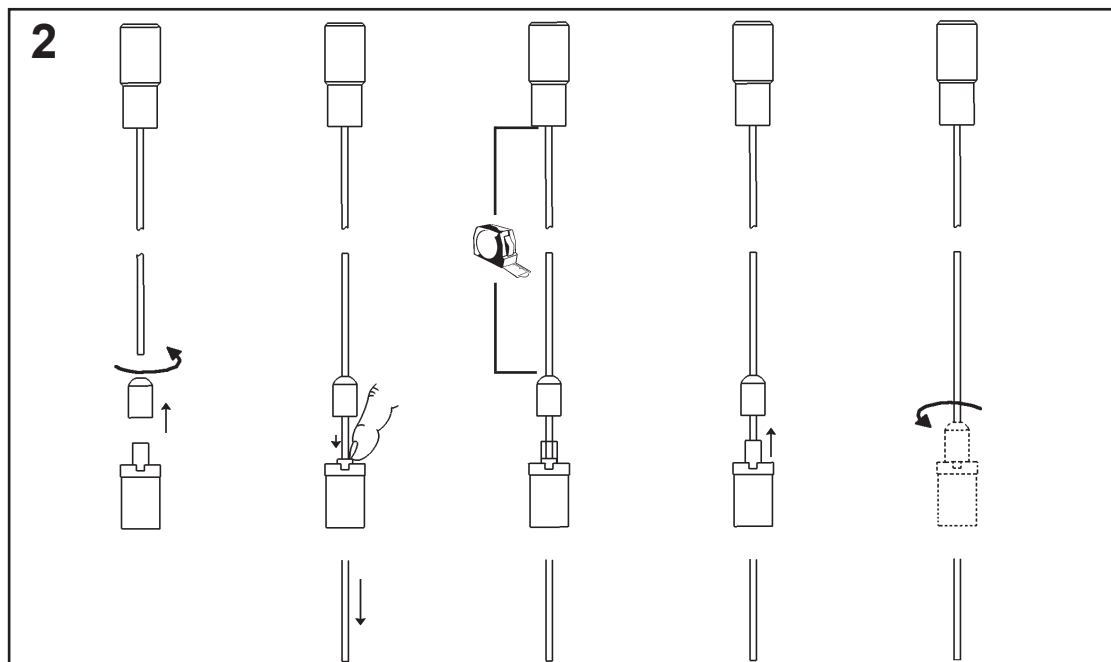
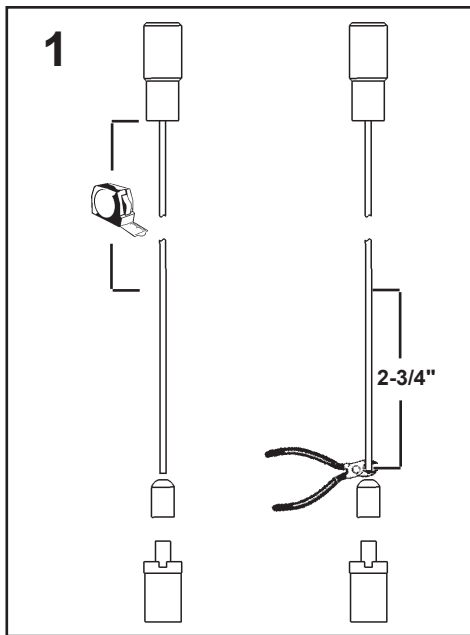

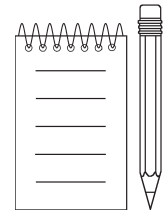

1 X  : 1746

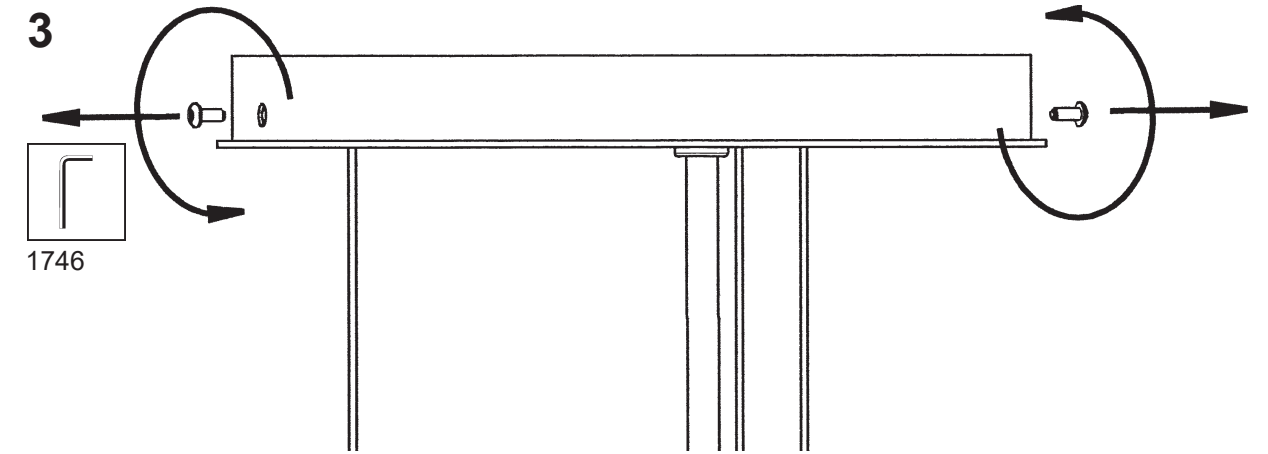



1746

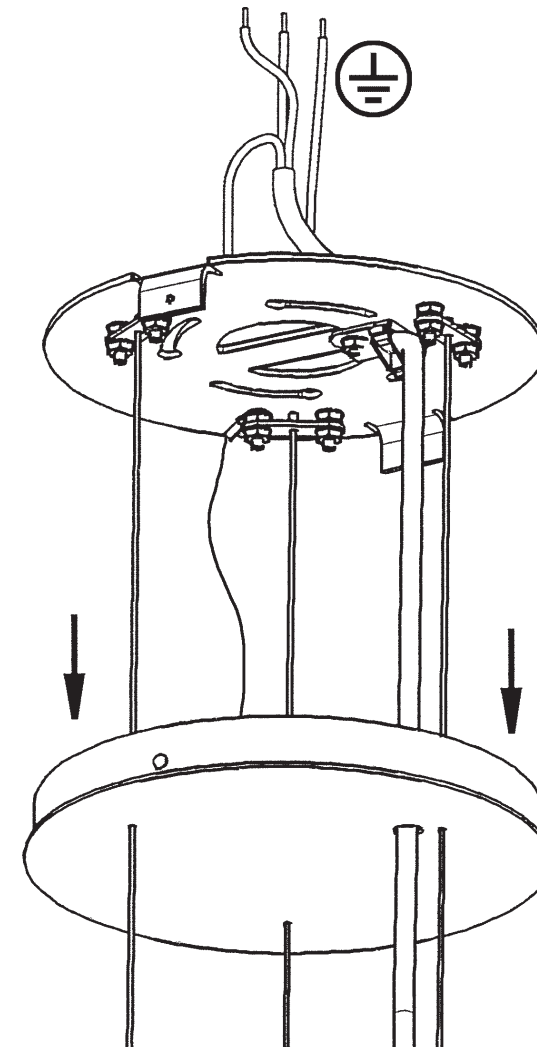

3

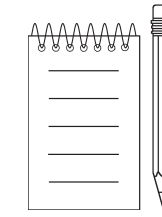
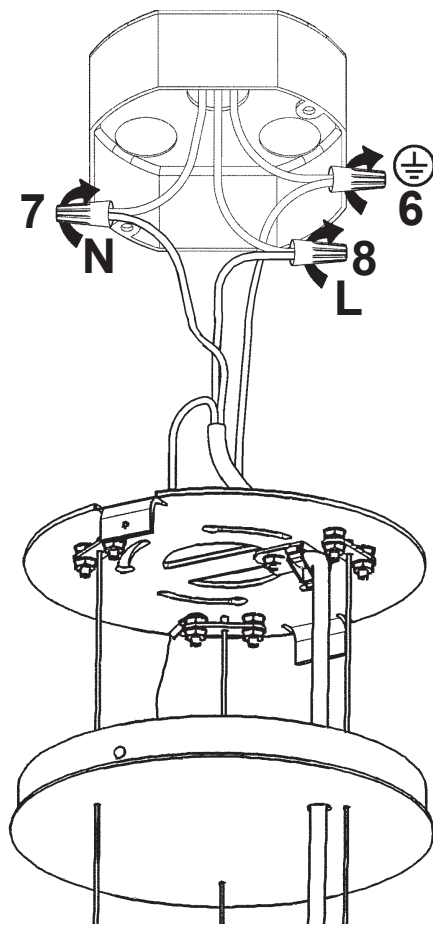
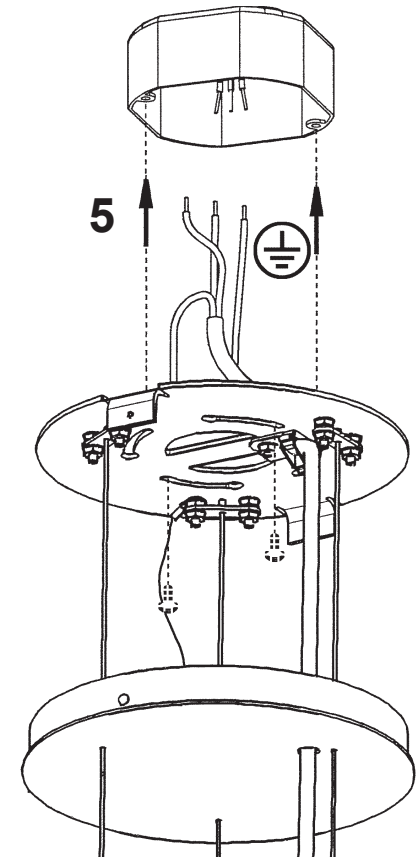

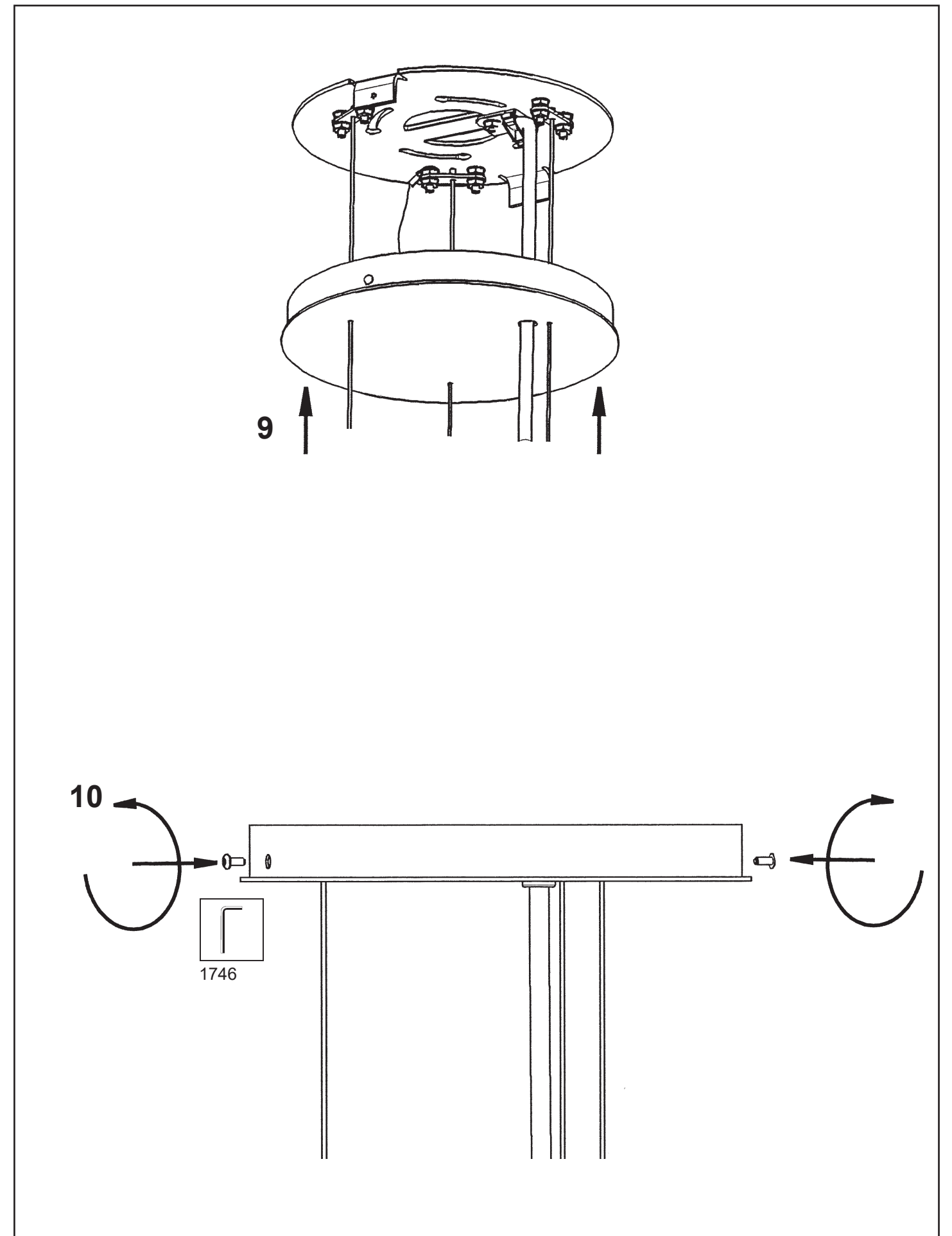
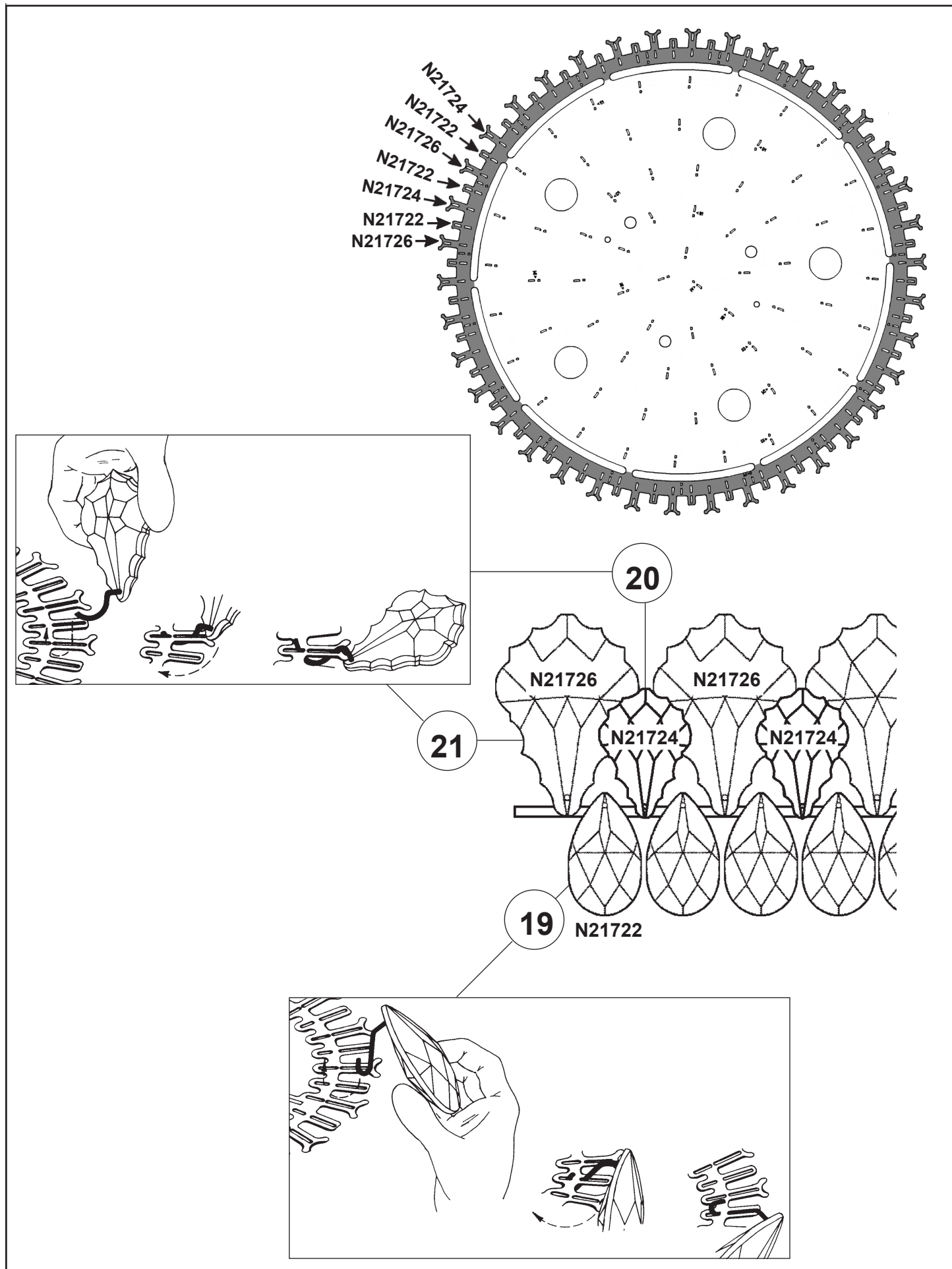
4



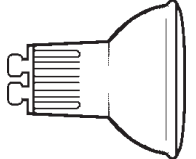

5 X  : GU10 50W MAX 

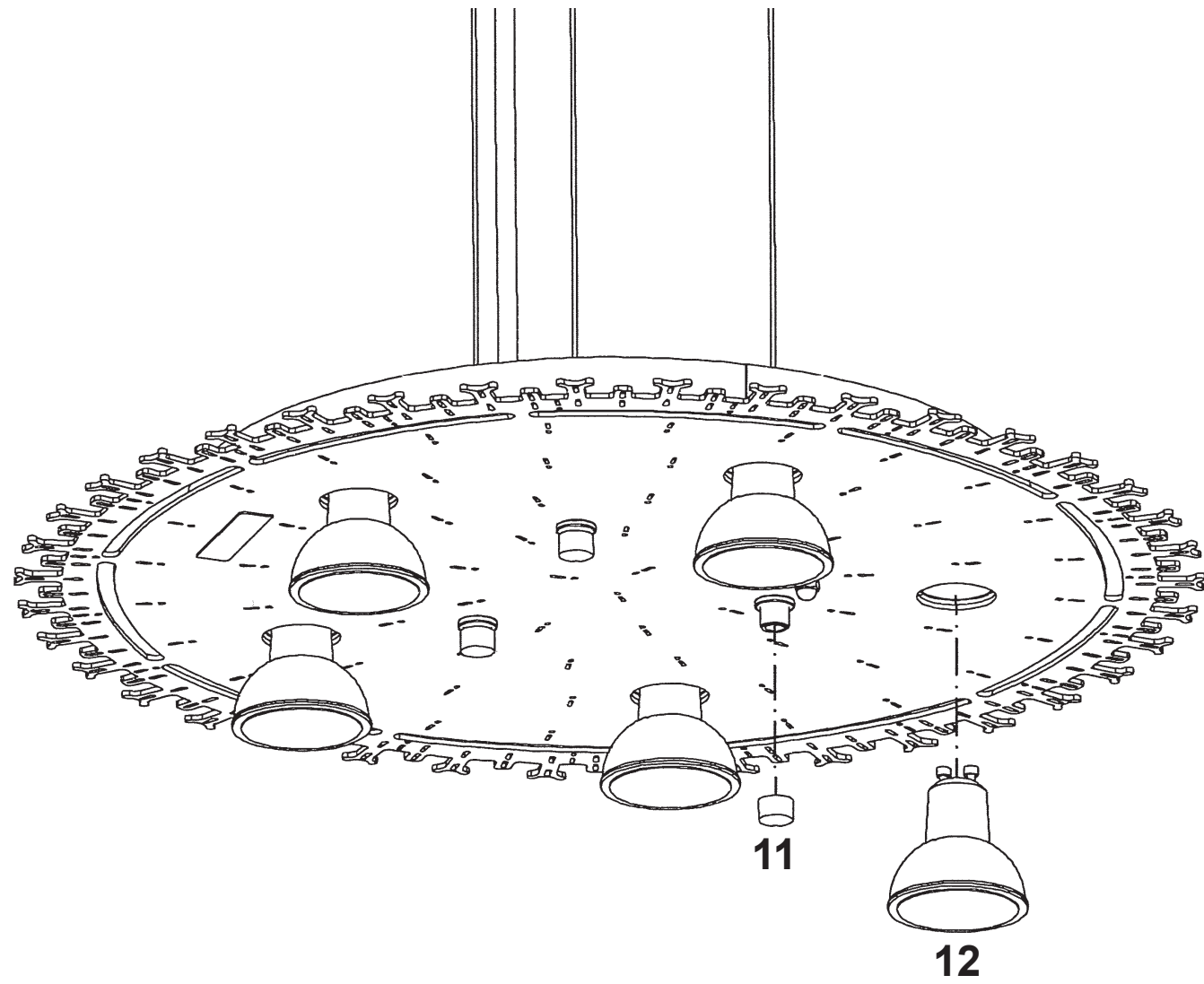

11

12

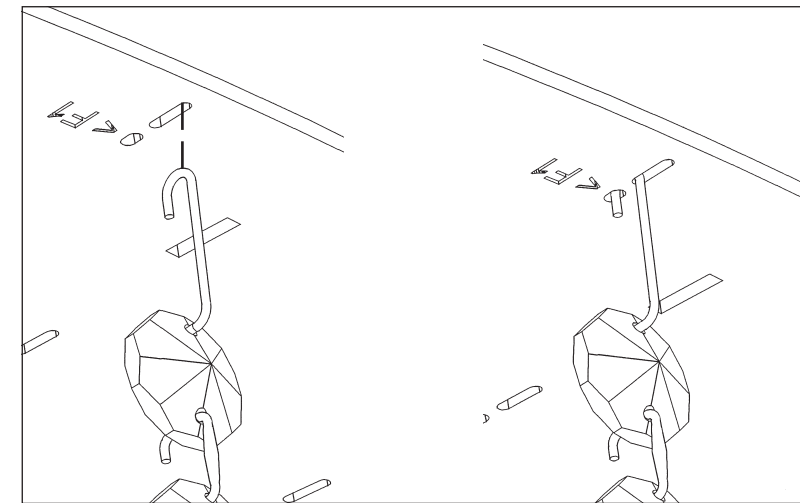
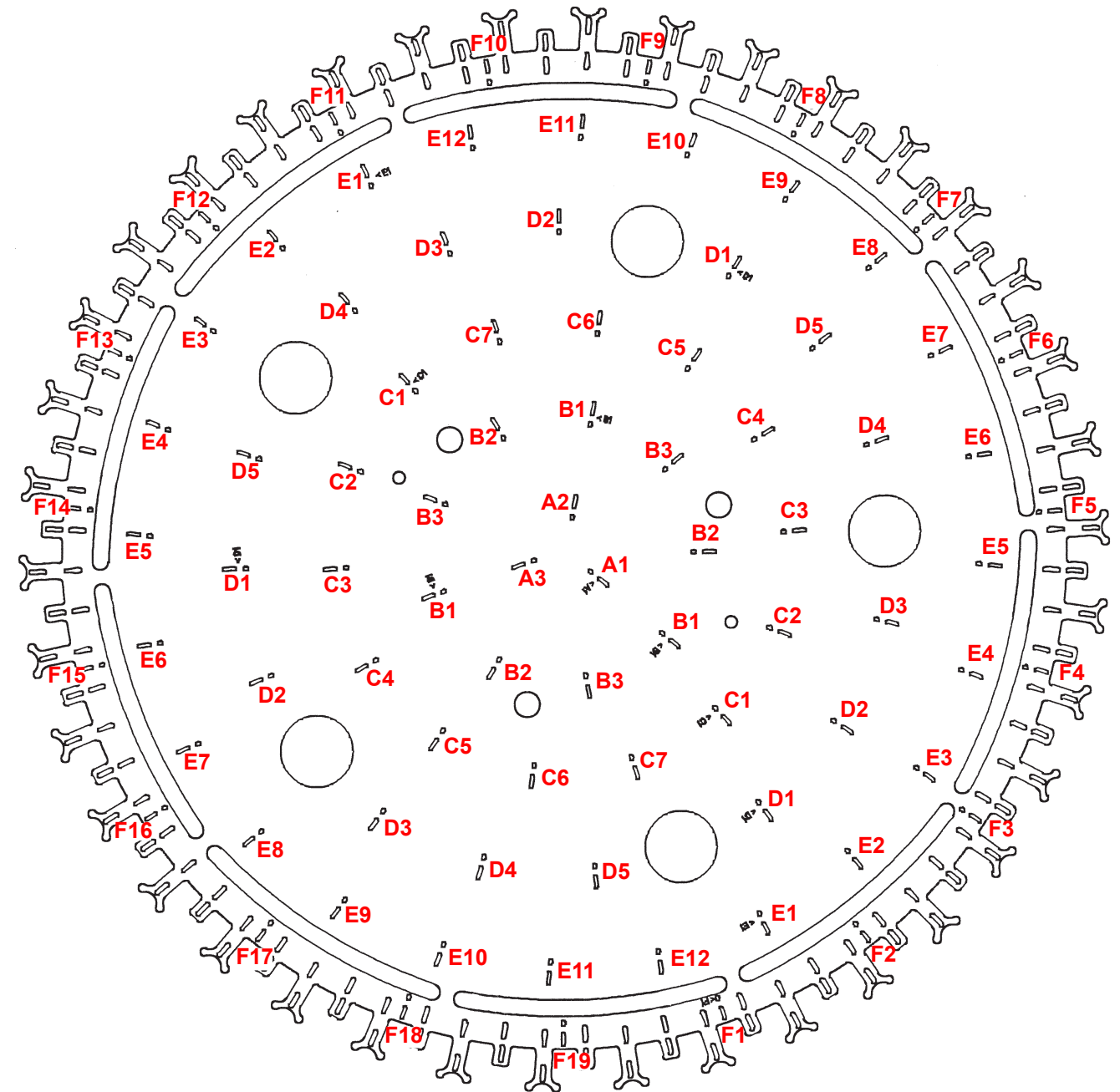

- 13 A1 - A3
- 14 B1 - B3
- 15 C1 - C7
- 16 D1 - D5
- 17 E1 - E12
- 18 F1 - F19

After hanging all trim, remove labels from crystals. If residue remains, wipe off crystal with a soft, dry cloth.